



**March 15, 2021
Council Meeting Proceedings**

Call to Order: The council meeting of the Mayor and City Council was called to order on March 15, 2021 at 7:00 p.m. with Mayor Martin presiding.

Roll Call: Present: CP Glenn, CM Robertson, CM Zinner, CM Boyer, CM Ringsaker and CM Martin.

The Pledge of Allegiance was recited and the opening prayer by Pastor Lynne Humphries-Russ of Susquehanna Charge of the United Methodist Church.

CM Ringsaker asked to make a friendly amendment to remove item 13A on this evening's agenda until further review. All in favor 6-0.

Approval of Minutes:

City Council Minutes – CM Zinner moved to approve the Council Meeting minutes of March 1, 2021. Second by CM Boyer. Motion carried 6-0.

Comments from Citizens on Agenda items:

Allen Fair of 3 Concord Place spoke in support of the upcoming Decoy Festival and the changes needed this year.

Suzanne Chadwick of 937 Nena Avenue spoke in support of the Jazz & Blues Fest and the changes to this year's event.

Lower Susquehanna Heritage Greenway (Bridgett Carty) wrote in support of the Pride of Baltimore II visit to Havre de Grace.

Appointments:

Economic Development Advisory Board re-appointment of Maria Terry.
Motion to approve by CM Robertson. Second by CM Martin. Motion carried 6-0.

Historic Preservation Commission re-appointment of Carol Nemeth.
Motion to approve by CM Zinner. Second by CM Robertson. Motion carried 6-0.

Planning Commission re-appointment of Harry Miller.
Motion to approve by CM Ringsaker. Second by CM Martin. Motion carried 6-0.

Oath of Office:

Water and Sewer Commission oath of office administered by Mayor Martin to James E. Clark who was appointed on January 19, 2021.

Presentation:

A presentation was given by Dr. Amy Rosenkrans on the marker that will be placed at Tydings Park on Saturday March 27th in representation of the Women's Suffragist.

Resolution:

Calendar Resolution 2021-05 concerning License Agreement for Sign at 669 Revolution Street was presented by CM Ringsaker.

A RESOLUTION BY THE MAYOR AND CITY COUNCIL OF HAVRE DE GRACE, MARYLAND PURSUANT TO SECTIONS 33 AND 34 OF THE CITY CHARTER AND THE LOCAL GOVERNMENT ARTICLE OF THE ANNOTATED CODE OF MARYLAND TO AUTHORIZE THE

MAYOR TO ENTER INTO A LICENSE FOR CONSTRUCTION AND INSTALLATION OF A FREE STANDING SIGN ON THE CITY RIGHT OF WAY AT 669 REVOLUTION STREET.

A motion to introduce was made by CM Ringsaker. Second by CM Robertson. Carried 6-0.

Motion to adopt by CP Glenn. Second by CM Ringsaker. After a roll call vote, the motion carried 6-0.

New Business:

Budget Amendment 2021-10: Ernest Burke Statue was introduced by CM Robertson.

Motion to approve by CM Robertson. Second by CM Martin. Motion carried 6-0.

Budget Amendment 2021-11: Taser Replacement Program was introduced by CM Robertson.

Motion to approve by CM Robertson. Second by CP Glenn. Motion carried 6-0.

Budget Amendment 2021-12: Critical Area was introduced by CM Robertson.

Motion to approve by CM Robertson. Second by CM Zinner. Motion carried 6-0.

Stephanie Noye presented on behalf of Budget Amendment 2021-12, and its positive impact on the Critical Area.

Special Events were presented by Patrick Sypolt as follows:

39th Annual Decoy & Wildlife Art Festival, May 1, 2021 8 a.m.–6:00 p.m., Decoy Museum Grounds

Motion to approve by CP Glenn. Second by CM Martin. Motion carried 6-0.

Defenders Day Celebration/Food Truck/Music Festival, May 1, 2021 (Rain Date – 5/2/21) 2:00 p.m.–9:00 p.m., Concord Point Park

Motion to approve by CM Robertson. Second by CM Ringsaker. Motion carried 6-0.

Pride of Baltimore II Visit, May 7-9, 2021 Late Afternoon Arrival (5/7), 9:00 a.m.-5:00 p.m. (5/8 & 5/9), Hutchins Memorial Park Dock

Motion to approve by CM Ringsaker. Second by CM Zinner. Motion carried 6-0.

Garden Mart, May 15-16, 2021 10:00 a.m.–5:00 p.m., Havre de Grace Maritime Museum

Motion to approve by CM Robertson. Second by CM Ringsaker. Motion carried 6-0.

Havre de Grace Jazz & Blues Fest, June 4-5, 2021 5:30 p.m.–7:30 p.m. (6/4) & 11:00 a.m.-7:00 p.m. (6/5) at Pennington Avenue and 8:00 p.m.–10:00 p.m. (6/4) & 1:00 p.m.-10:00 p.m. (6/5) at Concord Point Park

Motion to approve by CM Robertson. Second by CM Martin. Motion carried 6-0.

National Diabetes Initiative, Community Health Initiative Walk, June 5, 2021 (Rain Date – 6/12/21) 8:00 a.m.–11:30 a.m., Tydings Memorial Park (starting/ending point)

Motion to approve by CP Glenn. Second by CM Boyer. Motion carried 6-0.

Directors Report:

Mr. Patrick Sypolt, Director of Administration: Shared upcoming City events as follows:

On Wednesday, March 17th, St. Patrick's Day, the HdG Arts Collective invites you to get your "Irish on" as they present: Paddy's Green Shamrock Shore: Songs & Stories from Ireland Past & Present, featuring Feargal King; at the Cultural Center at the Opera House. Showtime is at 8:00 p.m. To purchase tickets please visit their website at: hdgoperahouse.org.

On Saturday, March 20th, the HdG Arts Collective presents: the Atomic Light Orchestra (ALO). This event has been moved to the State Theater of Havre de Grace, located at 325 St. John Street to accommodate the anticipated attendance and in keeping with proper COVID guidelines. Show time is 8:00 p.m. For tickets please visit either the State Theater or Opera House websites: statetheaterofhdg.com or hdgoperahouse.org.

On Sunday, March 21st, the HdG Arts Collective presents a Living History Portrayal: Verda Freeman Welcome: Ride the Welcome Wagon, featuring Janice Curtis Greene. Witness her remarkable journey, beginning on a truck farm in North Carolina during the Jim Crow era through the historical portrayal of her life by Master Storyteller, Janice Curtis Greene.

On Monday, March 22nd, at 7 p.m. join the Friends of Concord Point Lighthouse as they sponsor a free virtual lecture on Women Lighthouse Keepers by historian Mary Rasa. To reserve a spot for the lecture call 410-939-3213 or email director@concordpointlighthouse.org.

On Tuesday, March 23rd beginning at 7:00 p.m., the HdG Arts Collective invites you to join them for an informative and fascinating lecture by Dr. Amy Rosenkrans: Women in Politics: Then and Now Lecture and Panel Discussion. Dr. Rosenkrans will educate us on the history of the Suffragist movement in Harford County. Following the lecture, Dr. Rosenkrans will moderate a panel discussion with distinguished women elected officials who will relay their personal experiences in politics. Scheduled to attend: HdG City Council members: Casi Boyer and Carolyn Zinner; Aberdeen City Council member Sandra Landbeck and Maryland State Delegate Mary Ann Lisanti.

On Thursday, March 25th, the HdG Arts Collective presents “Iron Jawed Angels” with an introduction by our own HdG Police Chief Teresa Walter. Iron Jawed Angels is a 2004 American historical drama film that focuses on the American women’s suffrage movement during the 1910s and follows women’s suffrage leaders Alice Paul and Lucy Burns as they use peaceful and effective nonviolent strategies, tactics and dialogues to revolutionize the American feminist movement to grant women the right to vote. The film stars Hillary Swank as suffragist leader Alice Paul; Frances O’Connor as activist Lucy Burns; Julia Ormond as Inez Milholland and Anjelica Huston as Carrie Chapman Catt. The film received critical acclaim after the film premiered at the 2004 Sundance Film Festival. Showtime is 7:00 p.m. at the Cultural Center at the Opera House. The admission is free!

On Saturday, March 27th the public is invited to meet at the Cultural Center at the Opera House at 11:45 a.m. to march to the dedication celebration in Millard E. Tydings Memorial Park. The parade steps off promptly at noon from the Opera House and ends at the park where a plaque will be unveiled marking the spot where suffragist stopped and spoke during their march to Washington D.C. Participants are encouraged to come dressed as suffragists.

Later that same day, March 27th, the HdG July 4th Commission presents Bridgerton Inspired Paint Night at the Unlimited Art Studio at 102 N. Washington Street. Join your friends, do some painting, while supporting the July 4th Commission. Early registration is encouraged, the cost is \$25.00 and B.Y.O.B. is suggested. Please email: hdgjuly4th@gmail.com.

On Saturday, April 3rd, the HdG Recreation Committee will hold its annual Egg Hunt at the Concord Point Lighthouse in Have de Grace. A socially distant bunny will be available for photos. Masks must be worn by all in attendance age 7 and up.

Also on Saturday, April 3rd, it’s Opening Day for both the Steppingstone Museum and the Susquehanna Lock House Museum. Both will open their doors from 1:00 p.m. until 5:00 p.m.

Please visit our websites often for the latest information concerning the COVID-19. For a complete updated calendar of events for our City and participating venues, please visit our web sites at explorehavredegrace.com; hdgoperahouse.org; and havredegracemd.gov.

Shane Grimm, Director of Planning: The Bulle Rock Parcel K will be reviewed by the Planning Commission on Monday, March 22nd at 6:30pm.; the Commission will meet in person and the public is invited as space permits. The public can contact Mr. Grimm with questions if they cannot attend the meeting. The project is for 49 townhomes. They anticipate receiving a number of plans in the coming months for the remainder of Bulle Rock. Mr. Grimm also reminded citizens that grass cutting season is upon us, and citizens should keep their grass cut and use the warm weather as an opportunity for exterior repairs. Mr. Grimm explained that the City adopted the Property Maintenance Code many years ago, which allows City staff the ability to require repairs on properties with violations.

Erika Quesenbery Sturgill, Director of Economic Development: Shared a hyperlink to the Maryland Rural Broadband Connectivity Speed Survey at <https://maryland.speedsurvey.org> and encouraged residents and businesses to participate in order to ensure connectivity concerns in Havre de Grace are documented and addressed. The American Rescue Plan Act includes the Shuttered Venue Operators Grant program, which is for businesses that weren’t able to open with public showings such as movies and concerts; information will be shared with businesses as it becomes available.

George DeHority, Director of Finance: Thanked the Council members for approving the budget amendments. Shared the current financial condition of General Fund 1, Water/Sewer Fund 9 and Marina Fund 8 was presented. The General Fund 1 balance is \$5,816,500, which is \$2,168,900 ahead of budget. The Water/Sewer Fund 9 is \$705,300, which is a \$396,700 increase year-to-date. The Marina Fund 8 balance is \$1,095,300, which is a \$216,600 increase year-to-date.

Tim Whittie, Director of Public Works: Shared update on BG&E repairs to City streets. The alleyway behind Fountain Street and Evonik property is going to be regraded, drainage improved, and paved. The Aberdeen waterline project bids will be approved tomorrow. The RFP for the two sewer projects at Francis Street and Congress Street will go out this week. The three waterline projects will go out for a RFP next week. The bathroom decks at Hutchins Park have been completed. The Burns property porch will be replaced along with the side porch.

Chief Teresa Walter, Havre de Grace Police Department: Thanked the Council members for approving the budget amendment. Reminded folks again about identity theft and scams. Examples of identity theft can include someone used your information to file for unemployment, someone filed a Federal tax return using your information, or if you are a small business, someone claimed an economic stimulus payment perhaps for COVID-19 relief by using your information. The Federal Trade Commission has several sites you can refer to that will assist you with reporting and recovery from identity theft:

www.identitytheft.gov

IDTheftRecords@sba.gov (SBA – Small Business Administration)

disastercustomerservice@sba.gov

Chief Walters also spoke on thefts from vehicles. This too has been mentioned recently and folks were asked to please remove any valuables from their vehicle and lock their doors. Even if you lock your vehicle, do not keep purses, tablets, tools, sporting equipment, etc. in view. The Police Department doesn't want your vehicle broken into and damaged as well as items stolen. This includes work vehicles as well as personal vehicles. With the weather changing, more calls are coming in for thefts of items stolen from vehicles. In celebrating St. Patrick's Day do it wisely and have someone give you a ride. Do not drink and drive.

Business from Mayor Martin: The Ice Festival was a successful event. People were happy to attend. We are slowly emerging from the state of Covid we have been in for the past year. Thank you to Bambi Johnson and the members of the Havre de Grace Alliance for putting on this event. Mayor Martin spoke on Defenders Day giving a brief history of why we celebrate Defenders Day here in Havre de Grace. Thanked the Council for all the legislative action this evening.

Business from Council:

Council Member Boyer: Thanked the Alliance for putting on a great event this past weekend with the Ice Festival. Thanked Dr. Rosenkrans for her presentation this evening. The Street and Traffic Safety Committee will meet March 22nd online at 7:00 p.m.

Council Member Zinner: Thanked Bambi Johnson and the Alliance for the hard work that went into the Ice Festival. Thanked Dr. Rosenkrans as well. CM Zinner shared her and other citizens concerns on the Susquehanna Hose Company's decision to raffle off an AR15 gun in this year's fundraiser.

Council Member Robertson: This Wednesday the Economic Development Advisory Board will meet at 4:00 p.m. Thanked Julie and Bambi for a phenomenal event in the Ice Festival and the businesses for sponsoring the ice sculptures.

Council Member Martin: The Ice Festival was a success and people were excited to attend. On March 27th the American Legion Riders at Joseph L. Davis Post #47 is continuing its clothing and dry goods drop off event from 10:00 a.m. to 2:00 p.m. There will be baked goods, hot dogs, and soda for sale. Donations to the food pantry are also appreciated. To every Veteran or family member of a Veteran, if you want to be a part of a community the American Legion is looking for members.

Council Member Ringsaker: Had a great time at the Ice Festival and congratulated Todd at EZ Tobacco & Gifts and Bearwood Designs for the beautiful sculpture. The Planning Commission will be meeting on March 22nd. CM Ringsaker asked that drivers please be careful and watch for motorcyclists who are out now riding. CM Ringsaker spoke on the issue about the AR15 that has been a topic of conversation recently. CM Ringsaker is in support of the Susquehanna Hose Company and their choice to raffle off the gun of their choice to raise funds.

Business from Council President Glenn: Thanked the entire Havre de Grace Alliance for all they do. Personally thanked Officer Dan Petz for testifying on behalf of the City of Havre de Grace against HB 1089,

which proposes to eliminate School Resource Officers from our schools.

CP Glenn has the distinct honor of serving on the board for the Harford Community Action Agency. It is refreshing to see all the great work HCAA is doing to include providing energy assistance with fuel bills, water bills, rental assistance, etc. They also provide a community food pantry.

CP Glenn met with Stephen Snyder on his upcoming Eagle Scout Project. Stephen lives in Havre de Grace and is currently attending John Carroll High School. You may have run into him at the Farmer's Market as he runs a lemonade stand with his siblings. For his project he has chosen the Joe K. Trail because he enjoys hiking it with his family. He plans to replace the current trailhead sign with a more up to date sign at the entrance to the trail. The new sign will include a comprehensive and improved trail map that will help make the trail more accessible to visitors. He will also be doing some trail maintenance. This service project will undoubtedly enhance the Joe K. Trail and we wish him nothing but the best. Council President Glenn thanked Stephen for his service and looks forward to the day when he is awarded scouting's highest honor.

Warrior Proud Moments – Gavin Lloyd will be competing this weekend in the Maryland State Wrestling Championships in Ocean City. He has been training at a high level these past few weeks at GET FIT, and we wish him nothing but the best. CP Glenn announced that Mayor Martin scored a tying goal last evening at his hockey playoff game.

CP Glenn wished to extend his deepest sympathies to the family of Ruth Elliott whom was the first elected Mayor of Aberdeen in 1992. She was a great matriarch of Aberdeen and will be sorely missed.

Comments from Citizens:

Al Peteraf of 937 Nena Avenue thanked City Council for approving the re-appointment of Carol Nemeth. He is happy to see all the exciting things happening in the City.

James Miller of 320 Lewis Street spoke on the Susquehanna Hose Company raffle.

CP Glenn made a motion to adjourn at 9:43 p.m. with a second by CM Boyer. Motion carried 6-0.

Video recording of the City Council Meeting may be viewed online through the City of Havre de Grace YouTube channel.

Respectfully submitted,

Resa Laird

OK
upant

APPLICATION FOR APPOINTMENT TO
CITY SPONSORED ORGANIZATIONS
410-939-1800

Commission/Committee/Board Appointment Sought: Tourism Advisory Board

Name: Greg Pizzuto Date: 3/9/2021

Address: 115 N. MAIN STREET BEL AIR MD 21014

Home Phone: _____ Work Phone: [REDACTED]

Cell Phone: _____ E-Mail: GREG@VISITHARFORD.COM

Occupation: EXECUTIVE DIRECTOR

Place of Employment: VISIT HARFORD

Residency History: _____

Education Background: MBA KENT STATE UNIVERSITY

Special Interests: FLY FISHING

Personal Observations/Comments: _____

Committee/Commission/Board Sponsor: _____

Please return completed
form to:
City of Havre de Grace
Office of the Mayor
Attn: Ms. Resa Laird
711 Pennington Ave
Havre de Grace, MD 21078

CITY COUNCIL
OF
HAVRE DE GRACE, MARYLAND

RESOLUTION NO. 2021-

Introduced by _____ Council Member Ringsaker _____

A RESOLUTION BY THE MAYOR AND CITY COUNCIL OF HAVRE DE GRACE, MARYLAND, PURSUANT TO THE LOCAL GOVERNMENT ARTICLE OF THE ANNOTATED CODE OF MARYLAND AND SECTIONS 33 AND 34 OF THE CITY CHARTER FOR INSTALLATION OF A WHEELCHAIR ACCESS RAMP AND A RAISED PLATFORM DECK OVER A PORTION OF THE CITY RIGHT OF WAY AT 714 N. ADAMS STREET AND HOPPERS LANE

WHEREAS, the owner of 714 N. Adams Street, Havre de Grace, Maryland desires to utilize the City right of way to construct and install a wheelchair accessible ramp and raised platform deck for disabled residents; and

WHEREAS, the installation of the wheelchair access ramp and raised platform deck will promote the health, safety, and welfare of the public and serve the City's general purposes and is consistent with the use of other City rights-of-way for the construction of wheelchair access ramps; and

WHEREAS, the License was listed on the agenda for this City Council meeting in accordance with Resolution No. 2020-21; and

WHEREAS, the License attached as Exhibit A conforms with the requirements of Resolution No. 2020-21 and the Department of Planning Memorandum dated March 30, 2021 attached as Exhibit B describes the location of the wheelchair access ram and raised deck.

NOW THEREFORE, it is *determined, decided, and resolved by the City Council* that the Mayor is authorized to execute such License, which License will not become binding until it is signed by the Mayor and attested by the Director of Administration.

ADOPTED by the City Council of Havre de Grace, Maryland this 5th day of April, 2021.

SIGNED by the Mayor and attested by the Director of Administration this 6th day of April, 2021.

ATTEST:

THE MAYOR AND CITY COUNCIL
OF HAVRE DE GRACE, MARYLAND

Patrick D. Sypolt
Director of Administration

William T. Martin
Mayor

Introduced: 04/05/2021

Passed/Adopted: 04/05/2021

Effective Date: 04/06/2021

Exhibit A



City of Havre de Grace

711 PENNINGTON AVENUE, HAVRE DE GRACE, MARYLAND 21078

410-939-1800

WWW.HAVREDEGRACEMD.COM

LICENSE AGREEMENT

This AGREEMENT (“LICENSE”) is made this __ day of _____, 2021, between the Mayor and City Council of Havre de Grace, Maryland (“City”), and Aubrey D. Evelyn (“LICENSEE”).

WHEREAS, the LICENSEE is the owner of the property located at 714 N. Adams Street in Havre de Grace, Maryland; and,

WHEREAS, the LICENSEE has completed a permit application and has obtained approval from the City to encroach on City right-of-way to erect a wheelchair access ramp and deck that will be located in the City right-of-way for N. Adams Street and Hoppers Lane; and,

WHEREAS, the ramp and deck are in accordance with the description in the permit application, is not a permanent structure, and will not adversely impact the right-of-way; and

WHEREAS, the ramp and deck will promote the health, safety, and welfare of the public and serve the City’s general purposes; and

WHEREAS, the LICENSE was listed on the agenda at a City Council meeting and the City Council has approved the general terms of the LICENSE in accordance with Resolution No. 2007-10; and

WHEREAS, the Council has authorized the Mayor to execute such LICENSE, which LICENSE will not become binding until it is signed by the Mayor and attested by the Director of Administration.

NOW THEREFORE, in consideration of the promises contained herein, the parties agree as follows:

1. Property.

The City grants to the LICENSEE a LICENSE to encroach into the City's right-of-way for N. Adams Street and Hoppers Lane at 714 N. Adams Street.

2. Terms of Use.

LICENSEE agrees:

- a. Application for a LICENSE of City property shall be accompanied by a \$50.00 administrative fee.
- b. The LICENSEE is required to pay all costs associated with the LICENSE and the property, including but not limited to maintenance, repair, utilities, taxes, and insurance.
- c. The ramp and deck shall be maintained in good condition at all times.
- d. The City reserves the right to require the owner to remove the ramp and deck at any time at the owner's sole expense.
- e. The ramp and deck shall be removed when there is no longer a need for the ramp and deck.
- f. No portion of the ramp shall be located within the paved portion of Hoppers Lane.
- g. No vehicles shall be permitted to be parked on Hoppers Lane.
- h. The owner shall contact Ms. Utility prior to any digging or construction.

3. Indemnity.

The LICENSEE shall indemnify and save harmless the City and its employees and agents from all claims and demands, suits, actions, loss, damages, recoveries, judgments, costs and expenses in any manner arising out of or in connection with any injury, death, loss, or damage related to the LICENSEE's use of the right-of-way, the LICENSEE's conduct, or the LICENSEE's breach of the LICENSE.

4. Restoration.

The LICENSEE shall be responsible for all costs or expenses to restore the City right-of-way after termination of the permitted use. The City may undertake the restoration and all costs and expenses shall be assessed against the LICENSEE and the property owner, and such costs will become a lien on the property until fully paid.

5. Maintenance.

The LICENSEE shall maintain any facility or object in, above, or in the City right-of-way and related to the use in a manner that is attractive, clean, safe, workmanlike, and in good repair. The LICENSEE shall insure that the facility or object in, above, or in the City right-of-way related to the use is in compliance with all applicable federal, State, County and City laws, rules, ordinances, or regulation which are hereby incorporated into this Agreement.

6. Term

This Agreement shall remain in force for a period not to exceed five (5) years, and shall expire December 31, 2025, unless the City terminates or modifies this Agreement. In its sole discretion, the City Council may renew or extend this Agreement upon the request of the LICENSEE.

7. Permitted Use.

The temporary permitted use allowed by this Agreement is limited to the following: *use of a portion of the N. Adams Street and Hoppers Lane right-of-way for a wheelchair access ramp and deck.* Any disagreement between the parties about the type of use, the location of the use, or any special conditions required, shall be resolved by the City in its sole discretion.

8. Entire Agreement.

The Parties agree that this document contains the entire Agreement.

9. No Waiver

The LICENSEE agrees that the City's failure to enforce any of the terms herein shall not constitute a waiver.

10. Venue/Choice of Law

This is a Maryland contract and the parties hereto agree that the laws of Maryland shall apply to any disputes arising under the LICENSE. Harford County is the sole venue for any dispute.

11. No Assignment

This LICENSE may not be assigned by the LICENSEE without the express written consent of the City Council in its sole discretion, which continuation may be permitted if the proposed assignee continues the current use of the property for the remainder of the LICENSE term. Any renewal of this LICENSE must in accordance with Resolution 2007-10 or any superseding resolution or ordinance.

12. Specific Enforcement/Breach of Contract/Attorneys' Fees

In any legal action to enforce the terms of this LICENSE, for declaratory action, or to recover damages for breach of the terms of this LICENSE filed by any party, the City shall be entitled to recover reasonable attorneys' fees and costs from the LICENSEE or its successor or assigns for its successful prosecution or defense of such claims.

WITNESS our hands and seals.

WITNESS/ATTEST:

LICENSEE:

Signature

WITNESS/ATTEST:

MAYOR AND CITY COUNCIL OF
HAVRE DE GRACE, MARYLAND

Patrick D. Sypolt
Director of Administration

William T. Martin, Mayor

APPROVED AS TO LEGAL SUFFICIENCY:

April C. Ishak, City Attorney

THIS LICENSE AGREEMENT RELATES TO
PERMIT #20210334, IF APPLICABLE

Exhibit B



City of Havre de Grace

711 PENNINGTON AVENUE, HAVRE DE GRACE, MARYLAND 21078

410-939-1800

DEPARTMENT OF PLANNING
MEMORANDUM

March 30, 2021

TO: Steve Gamatoria
Chief of Staff

FROM: Shane P. Grimm, AICP
Director of Planning

Re: 714 N. Adams Street - License Agreement
Wheelchair Access Ramp and Raised Deck
Permit No. 20210334

The Department of Planning has received a permit application for a wheelchair access ramp and a raised platform/deck within the City right-of-way for N. Adams Street and Hoppers Lane. The ramp and deck are necessary for accessibility by disabled residents and will replace an existing covered porch. The Department of Public Works has reviewed the request and has no objections or comments. I have reviewed the permit application with the Planning Committee, and they have no objections or comments as well. A copy of the site plan and plans are attached to this memo.

The Department recommends the following conditions be included should the Mayor and City Council approve the request:

1. The ramp and deck shall be maintained in good condition at all times.
2. The City reserves the right to require the owner to remove the ramp and deck at any time at the owner's sole expense.
3. The ramp and deck shall be removed when there is no longer a need for the ramp and deck.
4. No portion of the ramp shall be located within the paved portion of Hoppers Lane.
5. No vehicles shall be permitted to be parked on Hoppers Lane.
6. The owner shall contact Ms. Utility prior to any digging or construction.

cc: Joe Conaway, DPW
Jeff Keithley, DPW
Marisa Willis, CFM, Planning Technician
Colleen Critzer, Permits Clerk

18031290
 LOCATION DRAWING
 714 N ADAMS STREET
 HARFORD COUNTY, MARYLAND
 03-12-2018 SCALE 1"=10'



HOPPER ALLEY
 (20' WIDE)

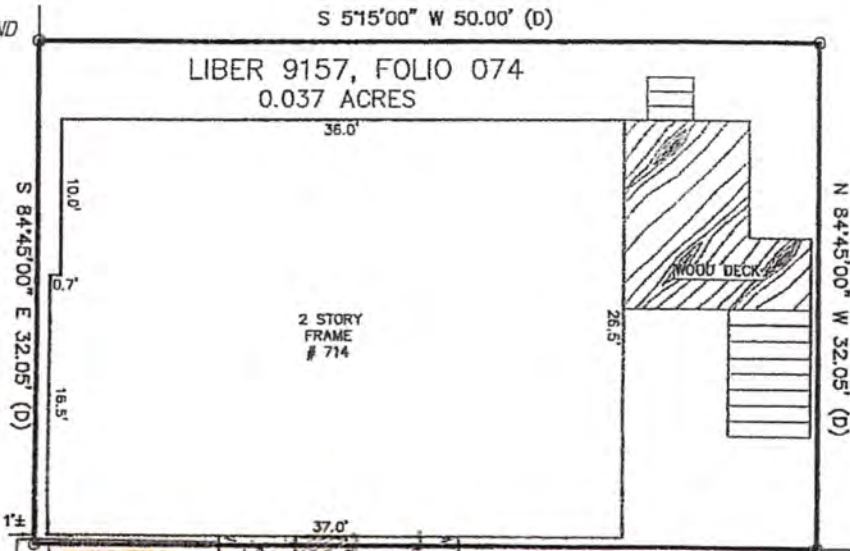

PLEASE NOTE
 This House Location Drawing is for informational purposes only. Per Maryland State Code it may not be relied upon to determine property boundaries and may not be used for building permits or construction.

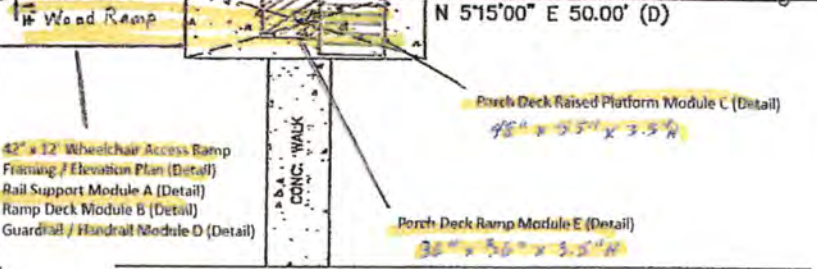

ADAMS STREET
 (70' R/W)

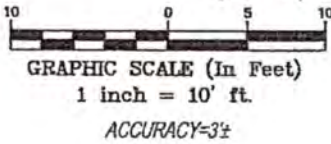

POINTS OF INTEREST:
 NONE VISIBLE.

CLIENT NUMBER: ELS-2018-79	DATE: 3/12/2018
BUYER: AUBREY EVELYN	
SELLER: JASON M. OBITZ	
CERTIFIED TO: AUBREY EVELYN	

POWERED BY:

www.surveystars.com

A LICENSEE EITHER PERSONALLY PREPARED THIS DRAWING OR WAS IN RESPONSIBLE CHARGE OVER ITS PREPARATION AND THE SURVEYING WORK REFLECTED IN IT.

LB# 21535
 www.exactamd.com
 o: 443.819.3994 | 1220 E Churchville Road, Suite 100 | Bel Air, MD 21014



714 N. ADAMS ST

Ramp and Porch Deck Traverse

Proposed location of wheelchair access ramp: View of the proposed ramp's traverse path as shown from the location of entry at the base of the ramp. Photo taken from the location one would be standing on the landing area just inside the paved surface of the Hoppers Alley (Lane) along the existing property line at the front of the home.



Proposed location of raised porch decking and deck threshold ramp: View of the existing porch deck and stairs showing the general direction of travel from the entry door to the proposed access ramp. The proposed 3.5" raised decking platform would be located in front of the entry door on top of the existing porch decking. A 36" inch threshold ramp would be located to the left of the raised decking along the front wall of the home heading in the direction of the left side of the porch.

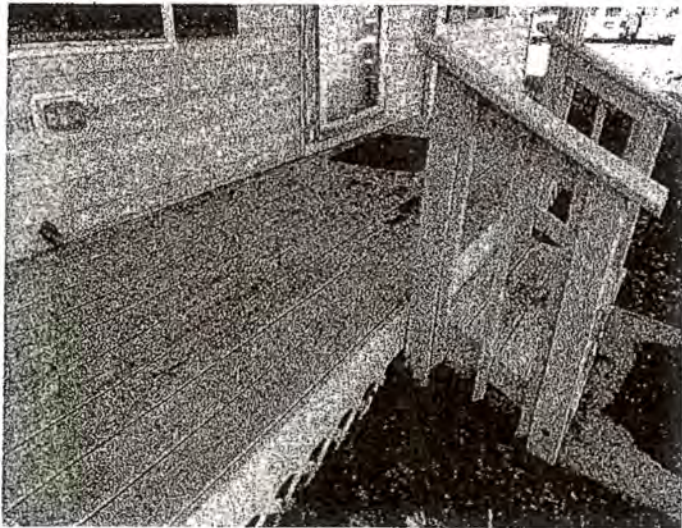

714 N Adams Street, Havre de Grace
Wheelchair Access Ramp
Framing and Elevation Plan

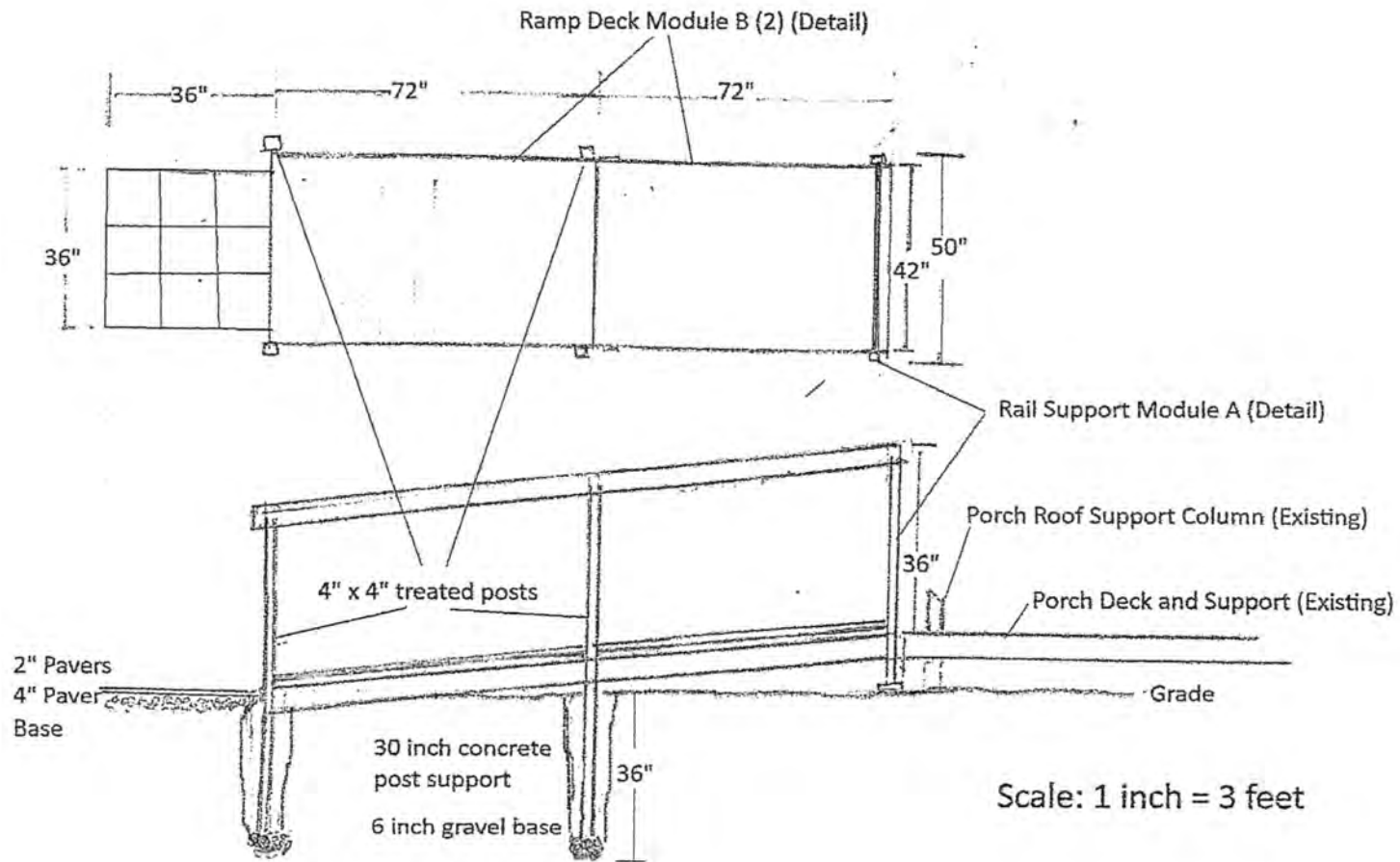

Rail Support Module A

Structure and Material Plan (short rail support 42 wide deck)

Components:

- 2 – 4" x 4" x 52" support posts (GC Pressure Treated)
- 2 – 1' x 1' x 3/4" treated plywood pads (GC Pressure Treated)
- 1 – 2" x 6" x 49 1/2" cross support (GC Pressure Treated)
- 6 – 3/8" x 6" galvanized carriage bolts

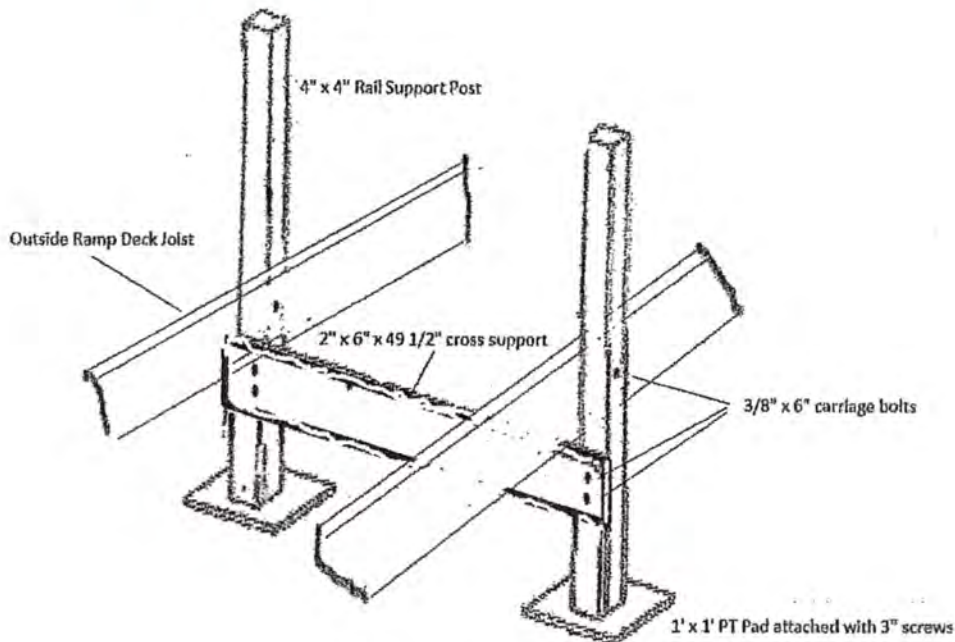

Construction

1. Height of 4x4 posts determined during construction (grade to final height of rail)
2. 1' x 1' x 3/4" pads are attached to base of post with (2) 3" HCR screws per post
3. Cross support attached to posts with (2) 3/8" x 6" carriage bolts per post
4. The ramp deck module is attached during construction to the support posts with (1) 3/8" x 6" carriage bolt per post through the outside joists of the deck ramp.

Ramp Deck Module B

Structure and Material Plan (72" long x 42" wide ramp deck module)

Components:

4 – 2" x 6" x 69" joists (GC Pressure Treated)

2 – 2" x 6" x 42" frame end pieces (GC Pressure Treated)

12 – 5/4" x 6" x 42" decking (GC Pressure Treated)

96 – 2 1/2" deck screws

16 – 3" deck screws

4 – 2x6 joist hangers (18 gauge Simpson or equivalent for use with treated lumber)

4 – 2x6 corner brackets (18 gauge Simpson or equivalent for use with treated lumber)

72 – joist hanger nails

Note: (2) Ramp Deck Module B assemblies are called for in this project

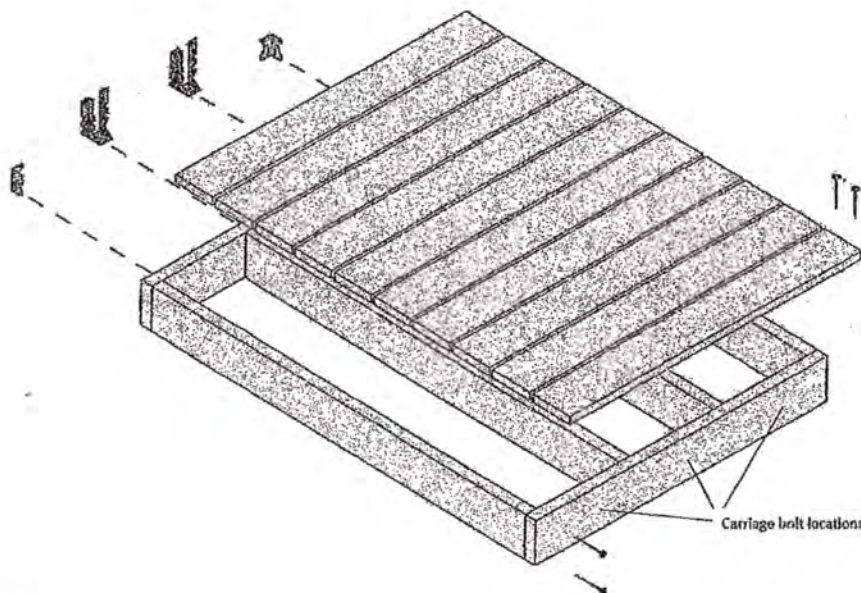

Construction

1. Joists spaced 13 1/2" apart on center.
2. Frame ends attached to joists with 3" deck screws from the outside of the frame.
3. Joist hangers and corner braces nailed to inside of frame.
4. Decking attached with 2 1/2" deck screws (8 screws per deck plank).
5. Frame attached to support structure with 3/8" galvanized carriage bolts, washers and nuts.
6. Frame end on upper most deck module is bolted to the face of the porch deck support outer joist with (3) 3/8" carriage bolts.

Porch Deck Module C

Structure and Material Plan (55" long x 48" wide x 3.5" high deck module)

Components:

- 4 – 2" x 4" x 52" joists (GC Pressure Treated)
- 2 – 2" x 4" x 48" frame end pieces (GC Pressure Treated)
- 10 – 5/4" x 6" x 48" decking (GC Pressure Treated)
- 96 – 2 1/2" deck screws
- 16 – 3" deck screws
- 8 – 1/4 in. x 5 in. Washer Head Exterior HCR Screws (or equivalent for use with treated lumber)

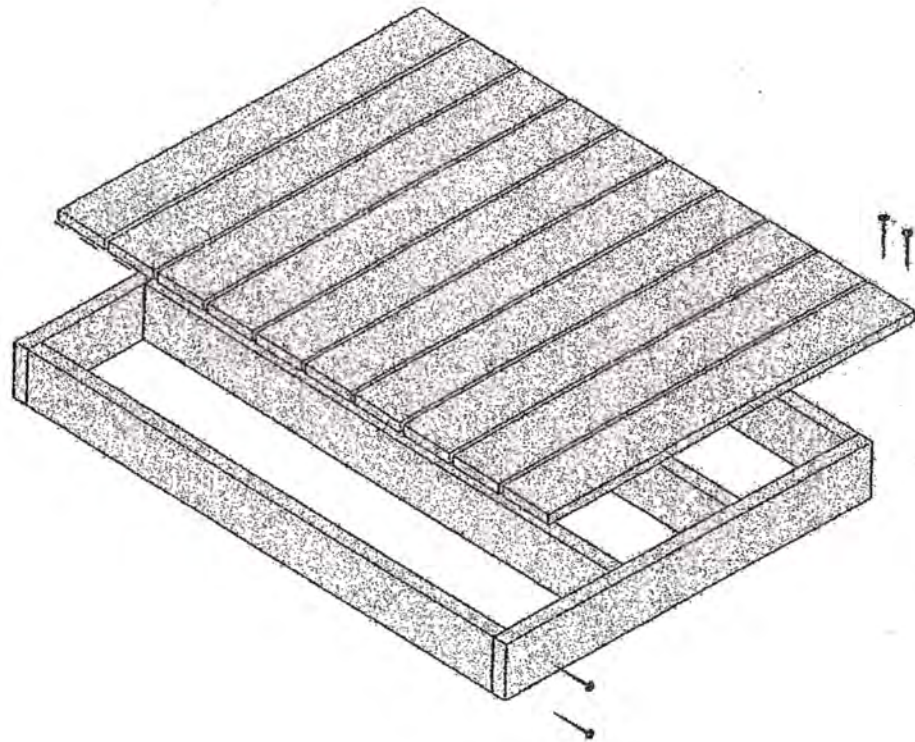

Construction

1. Joists and frame end pieces are ripped to 2 1/4" to achieve nominal finished deck height of 3 1/2".
2. Joists spaced 15 1/2" apart on center.
3. Frame ends attached to joists with 3" deck screws from the outside of the frame.
4. Joist hangers are not required as joists are supported by the existing porch deck.
5. Decking attached with 2 1/2" deck screws (8 screws per deck plank).
6. Frame attached to porch deck support structure with (8) 1/4" x 5" HCR screws.

Guardrail /Handrail Module D

Structure and Material Plan (72" long x 42" wide deck module – 36" high handrail)

Components:

- 2 – 2" x 6" x 72" handrail support rails (GC Pressure Treated)
- 2 – 2" x 4" x 72" guardrails (GC Pressure Treated)
- 34 – 2" x 2" x 30" spindles (GC Pressure Treated)
- 68 - 2 ½" HCR deck screws
- 16 – 3" HCR deck screws
- 2 – 1 ½" diameter x 6' aluminum handrails (white)
- 4 – aluminum handrail brackets with screws (white)
- 2 – aluminum rail returns with screws (white)

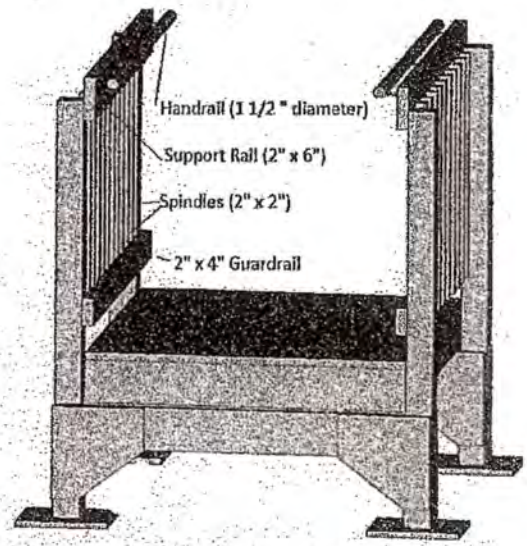
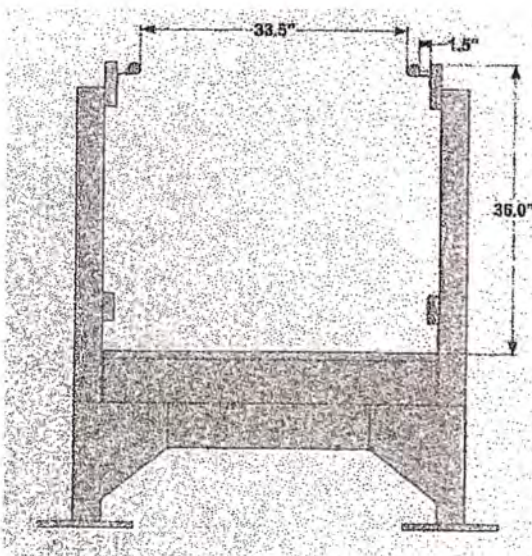

Construction

1. The 2" x 4" guardrail is installed 4 inches above the decking to allow for snow and debris removal from the deck surface.
2. The guard rail is attached to the support post with 3" HCR deck screws through the face of the board into the support post.
3. The 2" x 6" support rail is attached to the support post with 3" HCR deck screws with the top of the rail at 36" inches above the surface of the ramp decking.
4. The handrail is attached to the support rail with a handrail return at the open end of the ramp and handrail support brackets spaced every 3 ft along the support rail. The top of the handrail is to be 36" above the ramp decking.

Porch Deck Ramp Module E

Structure and Material Plan (36" long x 36" wide x 3.5" high adjustable height ramp module)

Components:

PVI ATH3636 Adjustable Height Threshold Ramp

- Durable welded aluminum construction.
- Slip resistant grooved aluminum surface.
- Accommodates wheelchairs and scooters with various wheel configurations.
- Maximum weight capacity of 400 lbs. for single axle and 800 lbs. for dual axle

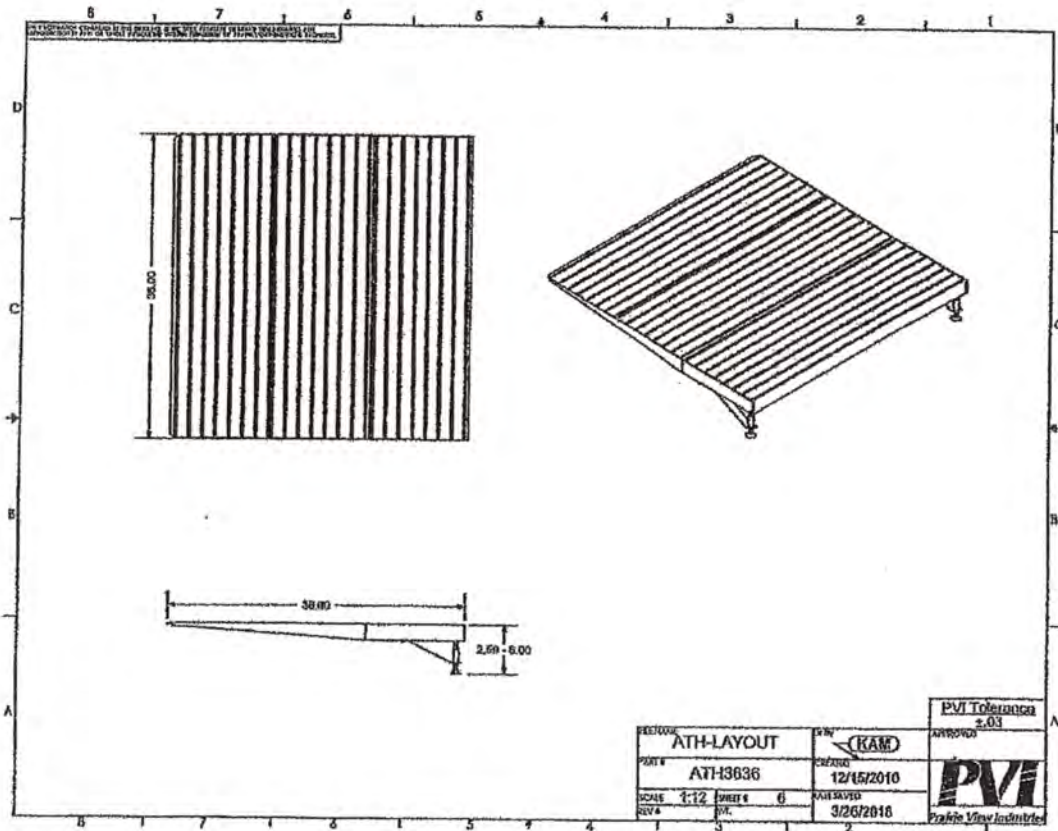

Construction

1. Height adjusted to final elevation to be level with the decking surfacing of the raised porch deck module and transition to the existing porch deck surface.
2. Anchored to the existing porch deck surface with 3" HCR decking screws

6

7

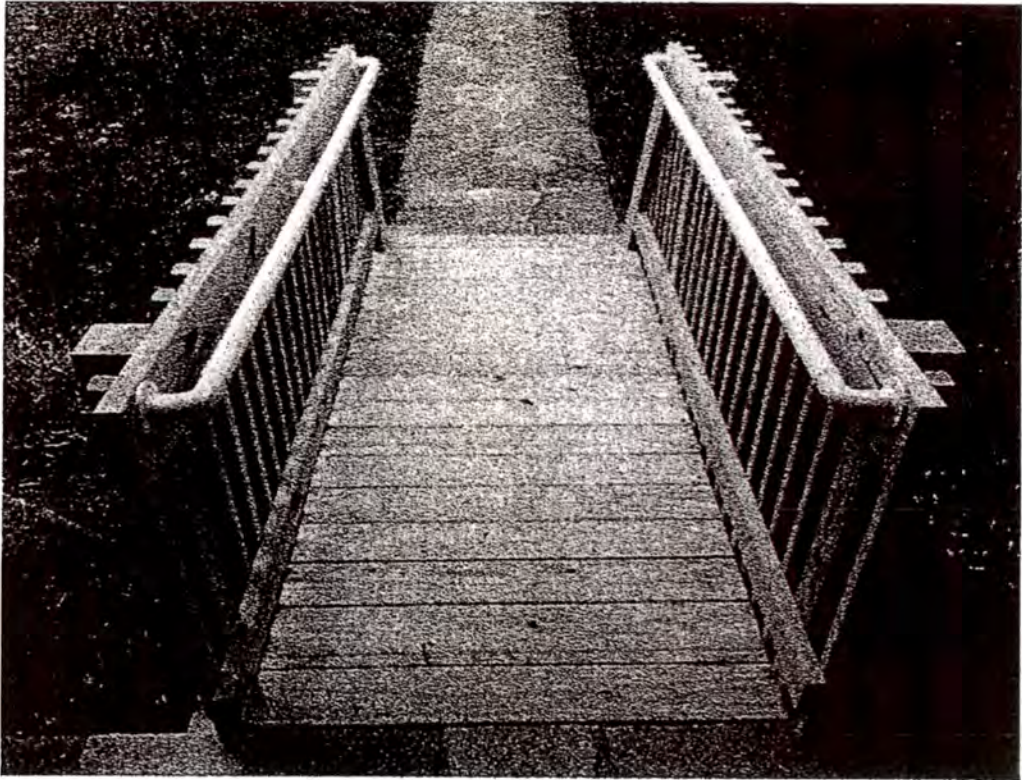

CITY COUNCIL
OF
HAVRE DE GRACE, MARYLAND

RESOLUTION NO. 2021-_____

Introduced by _____ Council Member Ringsaker

A RESOLUTION BY THE MAYOR AND CITY COUNCIL OF HAVRE DE GRACE, MARYLAND, PURSUANT TO THE LOCAL GOVERNMENT ARTICLE OF THE ANNOTATED CODE OF MARYLAND AND SECTIONS 33 AND 34 OF THE CITY CHARTER FOR INSTALLATION OF A PROJECTING SIGN/PUBLIC ART OVER A PORTION OF THE CITY RIGHT OF WAY AT 114 N. WASHINGTON STREET

WHEREAS, the owner of 114 N. Washington Street, Havre de Grace, Maryland desires to utilize the City right of way to construct and install a projecting sign/public art; and

WHEREAS, the installation of the projecting sign/public art will promote the health, safety, and welfare of the public and serve the City’s general purposes and is consistent with other signs and public art in the Downtown Business District; and

WHEREAS, the License was listed on the agenda for this City Council meeting in accordance with Resolution No. 2020-21; and

WHEREAS, the License attached as Exhibit A conforms with the requirements of Resolution No. 2020-21 and the Department of Planning Memorandum dated March 30, 2021 attached as Exhibit B describes the location of the projecting sign/public art.

NOW THEREFORE, it is *determined, decided, and resolved by the City Council* that the Mayor is authorized to execute such License, which License will not become binding until it is signed by the Mayor and attested by the Director of Administration.

37 *ADOPTED by the City Council* of Havre de Grace, Maryland this 5th day of April, 2021.

38

39 *SIGNED by the Mayor and attested by the Director of Administration* this 6th day of April, 2021.

40

41

42 ATTEST:

43

44

THE MAYOR AND CITY COUNCIL
OF HAVRE DE GRACE, MARYLAND

45

46 _____
Patrick D. Sypolt
47 Director of Administration

48

49

William T. Martin
Mayor

50

Introduced: 04/05/2021

51

Passed/Adopted: 04/05/2021

52

53

Effective Date: 04/06/2021

54

Exhibit A

55



City of Havre de Grace

58

711 PENNINGTON AVENUE, HAVRE DE GRACE, MARYLAND 21078
WWW.HAVREDEGRACEMD.COM

410-939-1800

59

60

LICENSE AGREEMENT

61

This AGREEMENT (“LICENSE”) is made this __ day of _____, 2021, between the

62

Mayor and City Council of Havre de Grace, Maryland (“City”), and 114 N. Washington LLC

63

(“LICENSEE”).

64

WHEREAS, the LICENSEE is the owner of the property located at 114 N. Washington

65

Street in Havre de Grace, Maryland; and,

66

WHEREAS, the LICENSEE has completed a permit application and has obtained approval

67

from the City to encroach on City right-of-way to erect a projecting sign/public art that will be

68

located in the City right-of-way for N. Washington Street; and,

69

WHEREAS, the sign/public art is in accordance with the description in the permit

70

application, is not a permanent structure, and will not adversely impact the right-of-way; and

71

WHEREAS, the sign will promote the health, safety, and welfare of the public and serve

72

the City’s general purposes; and

73

WHEREAS, the LICENSE was listed on the agenda at a City Council meeting and the City

74

Council has approved the general terms of the LICENSE in accordance with Resolution No. 2020-

75

21; and

76

WHEREAS, the Council has authorized the Mayor to execute such LICENSE, which

77

LICENSE will not become binding until the it is signed by the Mayor and attested by the Director

78

of Administration.

79 NOW THEREFORE, in consideration of the promises contained herein, the parties agree
80 as follows:

81 **1. Property.**

82 The City grants to the LICENSEE a LICENSE to encroach into the City's right-of-way in
83 front of the building located at 114 N. Washington Street.

84 **2. Terms of Use.**

85 LICENSEE agrees:

- 86 a. Application for a LICENSE of City property shall be accompanied by a \$50.00
87 administrative fee.
- 88 b. The LICENSEE is required to pay all costs associated with the LICENSE and the
89 property, including but not limited to maintenance, repair, utilities, taxes, and
90 insurance.
- 91 c. The sign shall be maintained in good condition at all times.
- 92 d. The City reserves the right to require the owner to remove the sign at any time at
93 the owner's sole expense.
- 94 e. The sign shall be removed upon the business ceasing operating at this location.

99
100 **3. Indemnity.**

101 The LICENSEE shall indemnify and save harmless the City and its employees and agents
102 from all claims and demands, suits, actions, loss, damages, recoveries, judgments, costs and
103 expenses in any manner arising out of or in connection with any injury, death, loss, or damage
104 related to the LICENSEE's use of the right-of-way, the LICENSEE's conduct, or the LICENSEE's
105 breach of the LICENSE.

106 **4. Restoration.**

107 The LICENSEE shall be responsible for all costs or expenses to restore the City right-of-
108 way after termination of the permitted use. The City may undertake the restoration and all costs

109 and expenses shall be assessed against the LICENSEE and the property owner, and such costs will
110 become a lien on the property until fully paid.

111 **5. Maintenance.**

112 The LICENSEE shall maintain any facility or object in, above, or in the City right-of-way
113 and related to the use in a manner that is attractive, clean, safe, workmanlike, and in good repair.
114 The LICENSEE shall insure that the facility or object in, above, or in the City right-of-way related
115 to the use is in compliance with all applicable federal, State, County and City laws, rules,
116 ordinances, or regulation which are hereby incorporated into this Agreement.

117 **6. Term**

118 This Agreement shall remain in force for a period of not more than five (5) years, and shall
119 expire December 31, 2025, unless the City terminates or modifies this Agreement. In its sole
120 discretion, the City Council may renew or extend this Agreement upon the request of the
121 LICENSEE.

122 **7. Permitted Use.**

123 The temporary permitted use allowed by this Agreement is limited to the following: *use of*
124 *a portion of the N. Washington Street right-of-way for a projecting sign/public art.* Any
125 disagreement between the parties about the type of use, the location of the use, or any special
126 conditions required, shall be resolved by the City in its sole discretion.

127 **8. Entire Agreement.**

128 The Parties agree that this document contains the entire Agreement.

129 **9. No Waiver**

130 The LICENSEE agrees that the City's failure to enforce any of the terms herein shall not
131 constitute a waiver.

132

133 **10. Venue/Choice of Law**

134 This is a Maryland contract and the parties hereto agree that the laws of Maryland shall
135 apply to any disputes arising under the LICENSE. Harford County is the sole venue for any
136 dispute.

137 **11. No Assignment**

138 This LICENSE may not be assigned by the LICENSEE without the express written consent
139 of the City Council in its sole discretion, which continuation may be permitted if the proposed
140 assignee continues the current use of the property for the remainder of the LICENSE term. Any
141 renewal of this LICENSE must in accordance with Resolution 2020-21 or any superseding
142 resolution or ordinance.

143 **12. Specific Enforcement/Breach of Contract/Attorneys' Fees**

144 In any legal action to enforce the terms of this LICENSE, for declaratory action, or to
145 recover damages for breach of the terms of this LICENSE filed by any party, the City shall be
146 entitled to recover reasonable attorneys' fees and costs from the LICENSEE or its successor or
147 assigns for its successful prosecution or defense of such claims.

148 WITNESS our hands and seals.

149
150

151 WITNESS/ATTEST:

LICENSEE:

152
153
154

Signature

155
156
157

158 WITNESS/ATTEST:

MAYOR AND CITY COUNCIL OF
HAVRE DE GRACE, MARYLAND

159
160
161
162
163

Patrick D. Sypolt
Director of Administration

William T. Martin, Mayor

164
165

166
167
168
169
170
171
172
173
174
175
176
177

APPROVED AS TO LEGAL SUFFICIENCY:

April C. Ishak, City Attorney

THIS LICENSE AGREEMENT RELATES TO
PERMIT #20210322, IF APPLICABLE

178

Exhibit B



City of Havre de Grace

711 PENNINGTON AVENUE, HAVRE DE GRACE, MARYLAND 21078

410-939-1800

179
180
181
182
183
184
185
186
187
188
189
190
191
192
193
194
195
196
197
198
199
200
201
202
203
204
205
206
207
208
209
210
211
212
213
214
215
216

DEPARTMENT OF PLANNING MEMORANDUM

March 30, 2021

TO: Steve Gamatoria
Chief of Staff

FROM: Shane P. Grimm, AICP
Director of Planning

**Re: 114 N. Washington Street - License Agreement
Public Art/Sign in Right-of-Way
Permit No. 20210322**

The Department of Planning has received a permit application for a projecting sign/public art within the City right-of-way for 114 N. Washington Street, the location of the Vintage Cafe. The advertising portion of the Sign Code meets requirements for size and height. The Department of Public Works has reviewed the request and has no objections or comments. I have reviewed the permit application with the Planning Committee, and they have no objections or comments as well. A copy of the site plan and graphic of the sign is attached to this memo.

The Department recommends the following conditions be included should the Mayor and City Council approve the request:

1. The sign shall be maintained in good condition at all times.
2. The City reserves the right to require the owner to remove the sign at any time at the owner's sole expense.
3. The sign shall be removed upon the business ceasing operating at this location.

cc: Joe Conaway, DPW
Jeff Keithley, DPW
Marisa Willis, CFM, Planning Technician
Colleen Critzer, Permits Clerk

April Burrit
DESIGN Illustration

APRILBURRIL-ARTIST.WEEBLY.COM
APRILBURRIL@GMAIL.COM • 443.206.0274
316 SOUTH WASHINGTON ST.
HAVRE DE GRACE, MD 21078

Date: 12/29/20
Proof #1
Sign Lettering

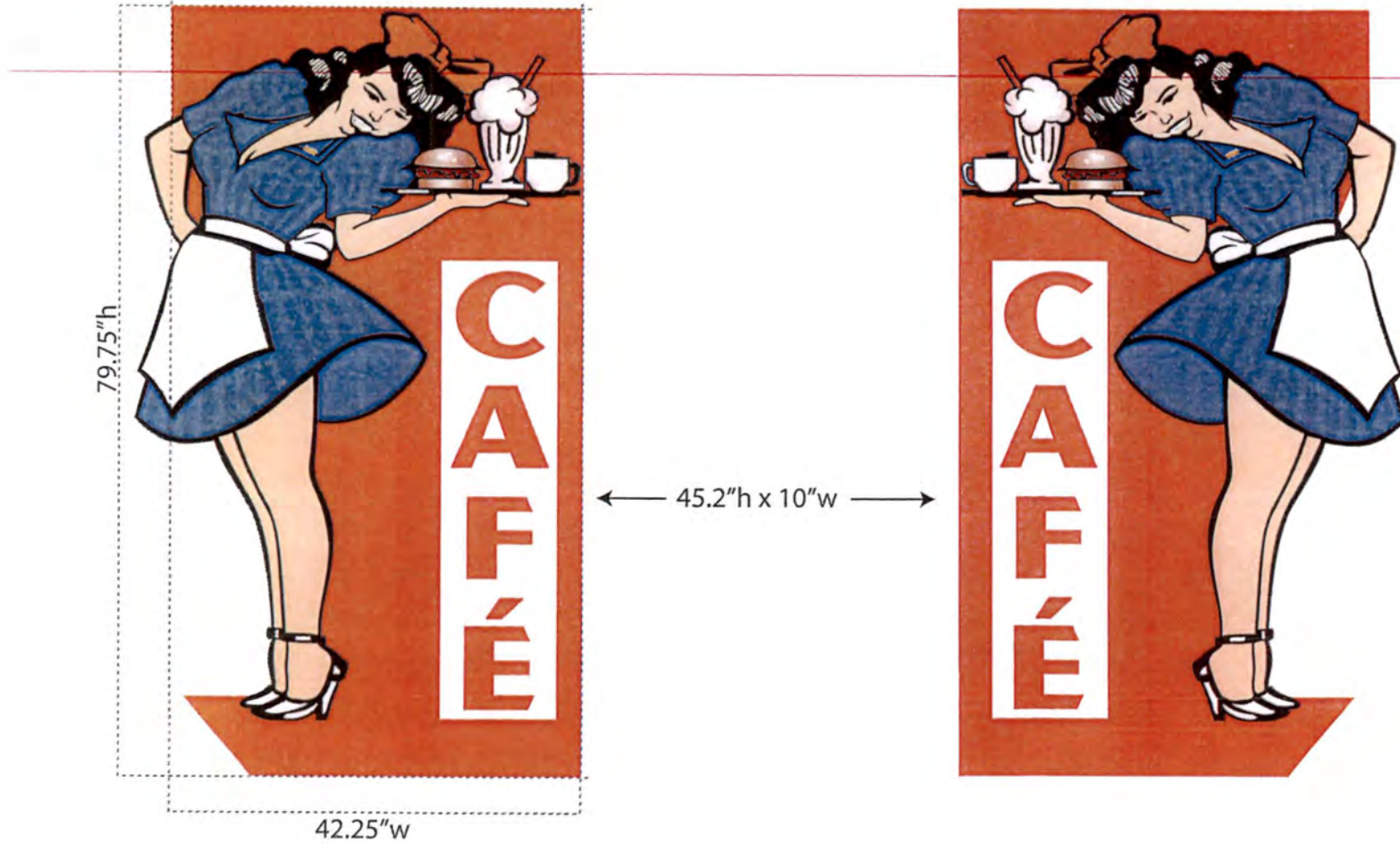

3/8/2021

GVC_SignComp.jpg



<https://mail.google.com/mail/u/0/?shva=1#inbox/FMfcgxlsmkhgrgCgJPjPrqItVxrmrhV?projector=1&messagePartId=0.2>

1/1

218

219

3/2/2021

0302211051_HDR.jpg



<https://mail.google.com/mail/u/1/#inbox?projector=1>

1/1

220

CITY COUNCIL
OF
HAVRE DE GRACE, MARYLAND

RESOLUTION NO. 2021-

Introduced by _____ Council Member Ringsaker _____

A RESOLUTION BY THE MAYOR AND CITY COUNCIL OF HAVRE DE GRACE, MARYLAND, PURSUANT TO THE LOCAL GOVERNMENT ARTICLE OF THE ANNOTATED CODE OF MARYLAND AND SECTIONS 33 AND 34 OF THE CITY CHARTER FOR INSTALLATION OF A FENCE OVER A PORTION OF THE CITY RIGHT OF WAY FOR REVOLUTION STREET ADJACENT TO THE PROPERTY LOCATED AT 428 S. WASHINGTON STREET

WHEREAS, the owner of 428 S. Washington Street, Havre de Grace, Maryland desires to utilize the City right of way to construct and install a 3-foot tall decorative fence which encroaches on the City right-of-way on Revolution Street; and

WHEREAS, the installation of the fence will promote the health, safety, and welfare of the public and serve the City’s general purposes and is consistent with other fences located within the City rights-of-way; and

WHEREAS, the License was listed on the agenda for this City Council meeting in accordance with Resolution No. 2020-21; and

WHEREAS, the License attached as Exhibit A conforms with the requirements of Resolution No. 2020-21 and the Department of Planning Memorandum dated March 30, 2021 attached as Exhibit B describes the location of the fence.

NOW THEREFORE, it is *determined, decided, and resolved by the City Council* that the Mayor is authorized to execute such License, which License will not become binding until it is signed by the Mayor and attested by the Director of Administration.

39 *ADOPTED by the City Council of Havre de Grace, Maryland this 5th day of April, 2021.*

40
41 *SIGNED by the Mayor and attested by the Director of Administration this 6th day of April, 2021.*

42
43
44 ATTEST: THE MAYOR AND CITY COUNCIL
45 OF HAVRE DE GRACE, MARYLAND
46

47
48 _____
49 Patrick D. Sypolt
50 Director of Administration

William T. Martin
Mayor

51
52 Introduced: 04/05/2021
53 Passed/Adopted: 04/05/2021
54
55 Effective Date: 04/06/2021

56

Exhibit A



City of Havre de Grace

711 PENNINGTON AVENUE, HAVRE DE GRACE, MARYLAND 21078

410-939-1800

WWW.HAVREDEGRACEMD.COM

LICENSE AGREEMENT

This AGREEMENT ("LICENSE") is made this __ day of _____, 2021, between the Mayor and City Council of Havre de Grace, Maryland ("City"), and Durphey Poe, Jr. ("LICENSEE").

WHEREAS, the LICENSEE is the owner of the property located at 428 S. Washington Street in Havre de Grace, Maryland; and,

WHEREAS, the LICENSEE has completed a permit application and has obtained approval from the City to encroach on City right-of-way to erect a fence that will be located in the City right-of-way for Revolution Street; and,

WHEREAS, the fence is in accordance with the description in the permit application, is not a permanent structure, and will not adversely impact the right-of-way; and

WHEREAS, the LICENSE was listed on the agenda at a City Council meeting and the City Council has approved the general terms of the LICENSE in accordance with Resolution No. 2020-21; and

WHEREAS, the Council has authorized the Mayor to execute such LICENSE, which LICENSE will not become binding until it is signed by the Mayor and attested by the Director of Administration.

79 NOW THEREFORE, in consideration of the promises contained herein, the parties agree
80 as follows:

81 **1. Property.**

82 The City grants to the LICENSEE a LICENSE to encroach into the City's right-of-way for
83 Revolution Street at 428 S. Washington Street.

84 **2. Terms of Use.**

85 LICENSEE agrees:

- 86 a. Application for a LICENSE of City property shall be accompanied by a \$50.00
87 administrative fee.
- 88 b. The LICENSEE is required to pay all costs associated with the LICENSE and the
89 property, including but not limited to maintenance, repair, utilities, taxes, and
90 insurance.
- 91 c. The fence shall be maintained in good condition at all times.
- 92 d. The City reserves the right to require the owner to remove the fence at any time at
93 the owner's sole expense.
- 94 e. The owner shall contact Ms. Utility prior to any digging or construction.

99
100 **3. Indemnity.**

101 The LICENSEE shall indemnify and save harmless the City and its employees and agents
102 from all claims and demands, suits, actions, loss, damages, recoveries, judgments, costs and
103 expenses in any manner arising out of or in connection with any injury, death, loss, or damage
104 related to the LICENSEE's use of the right-of-way, the LICENSEE's conduct, or the LICENSEE's
105 breach of the LICENSE.

106 **4. Restoration.**

107 The LICENSEE shall be responsible for all costs or expenses to restore the City right-of-
108 way after termination of the permitted use. The City may undertake the restoration and all costs

109 and expenses shall be assessed against the LICENSEE and the property owner, and such costs will
110 become a lien on the property until fully paid.

111 **5. Maintenance.**

112 The LICENSEE shall maintain any facility or object in, above, or in the City right-of-way
113 and related to the use in a manner that is attractive, clean, safe, workmanlike, and in good repair.
114 The LICENSEE shall insure that the facility or object in, above, or in the City right-of-way related
115 to the use is in compliance with all applicable federal, State, County and City laws, rules,
116 ordinances, or regulation which are hereby incorporated into this Agreement.

117 **6. Term**

118 This Agreement shall remain in force for a period not to exceed five (5) years, and shall
119 expire December 31, 2025, unless the City terminates or modifies this Agreement. In its sole
120 discretion, the City Council may renew or extend this Agreement upon the request of the
121 LICENSEE.

122 **7. Permitted Use.**

123 The temporary permitted use allowed by this Agreement is limited to the following: *use of*
124 *a portion of the Revolution Street right-of-way for a fence.* Any disagreement between the parties
125 about the type of use, the location of the use, or any special conditions required, shall be resolved
126 by the City in its sole discretion.

127 **8. Entire Agreement.**

128 The Parties agree that this document contains the entire Agreement.

129 **9. No Waiver**

130 The LICENSEE agrees that the City's failure to enforce any of the terms herein shall not
131 constitute a waiver.

132 **10. Venue/Choice of Law**

133 This is a Maryland contract and the parties hereto agree that the laws of Maryland shall
134 apply to any disputes arising under the LICENSE. Harford County is the sole venue for any
135 dispute.

136 **11. No Assignment**

137 This LICENSE may not be assigned by the LICENSEE without the express written consent
138 of the City Council in its sole discretion, which continuation may be permitted if the proposed
139 assignee continues the current use of the property for the remainder of the LICENSE term. Any
140 renewal of this LICENSE must in accordance with Resolution 2020-21 or any superseding
141 resolution or ordinance.

142 **12. Specific Enforcement/Breach of Contract/Attorneys' Fees**

143 In any legal action to enforce the terms of this LICENSE, for declaratory action, or to
144 recover damages for breach of the terms of this LICENSE filed by any party, the City shall be
145 entitled to recover reasonable attorneys' fees and costs from the LICENSEE or its successor or
146 assigns for its successful prosecution or defense of such claims.

147 WITNESS our hands and seals.

148

149 WITNESS/ATTEST:

150

151

152 _____

153

154

155

156 WITNESS/ATTEST:

157

158

159

160 _____

161 Patrick D. Sypolt
162 Director of Administration

LICENSEE:

Signature

MAYOR AND CITY COUNCIL OF
HAVRE DE GRACE, MARYLAND

William T. Martin, Mayor

163 APPROVED AS TO LEGAL SUFFICIENCY:

164

165

166 _____
April C. Ishak, City Attorney

167

168

169 THIS LICENSE AGREEMENT RELATES TO

170 PERMIT #20210338, IF APPLICABLE

171

172

173

174

Exhibit B

17



City of Havre de Grace

17

177

711 PENNINGTON AVENUE, HAVRE DE GRACE, MARYLAND 21078
WWW.HAVREDEGRACEMD.COM

410- 939-1800

178

179

DEPARTMENT OF PLANNING MEMORANDUM

180

181

182 March 30, 2021

183

184

185 TO: Steve Gamatoria
186 Chief of Staff

187

188 FROM: Shane P. Grimm, AICP
189 Director of Planning

190

191

192 **Re: 428 S. Washington Street - License Agreement**
193 **Fence in Right-of-Way**
194 **Permit No. 20210338**

195

196 The Department of Planning has received a permit application for a 3-foot tall picket fence within
197 the right-of-way for Washington Street. The Department of Public Works has reviewed the request
198 and has no objections or comments. I have reviewed the permit application with the Planning
199 Committee, and they have no objections or comments as well. A copy of the site plan is attached
200 to this memo.

201

202 The Department recommends the following conditions be included should the Mayor and City
203 Council approve the request:

204

- 205 1. The fence shall be maintained in good condition at all times.
- 206 2. The City reserves the right to require the owner to remove the fence at any time at the
207 owner's sole expense.
- 208 3. The owner shall contact Ms. Utility prior to any digging or construction.

209

210 cc: Joe Conaway, DPW
211 Jeff Keithley, DPW
212 Marisa Willis, CFM, Planning Technician
213 Colleen Critzer, Permits Clerk
214
215

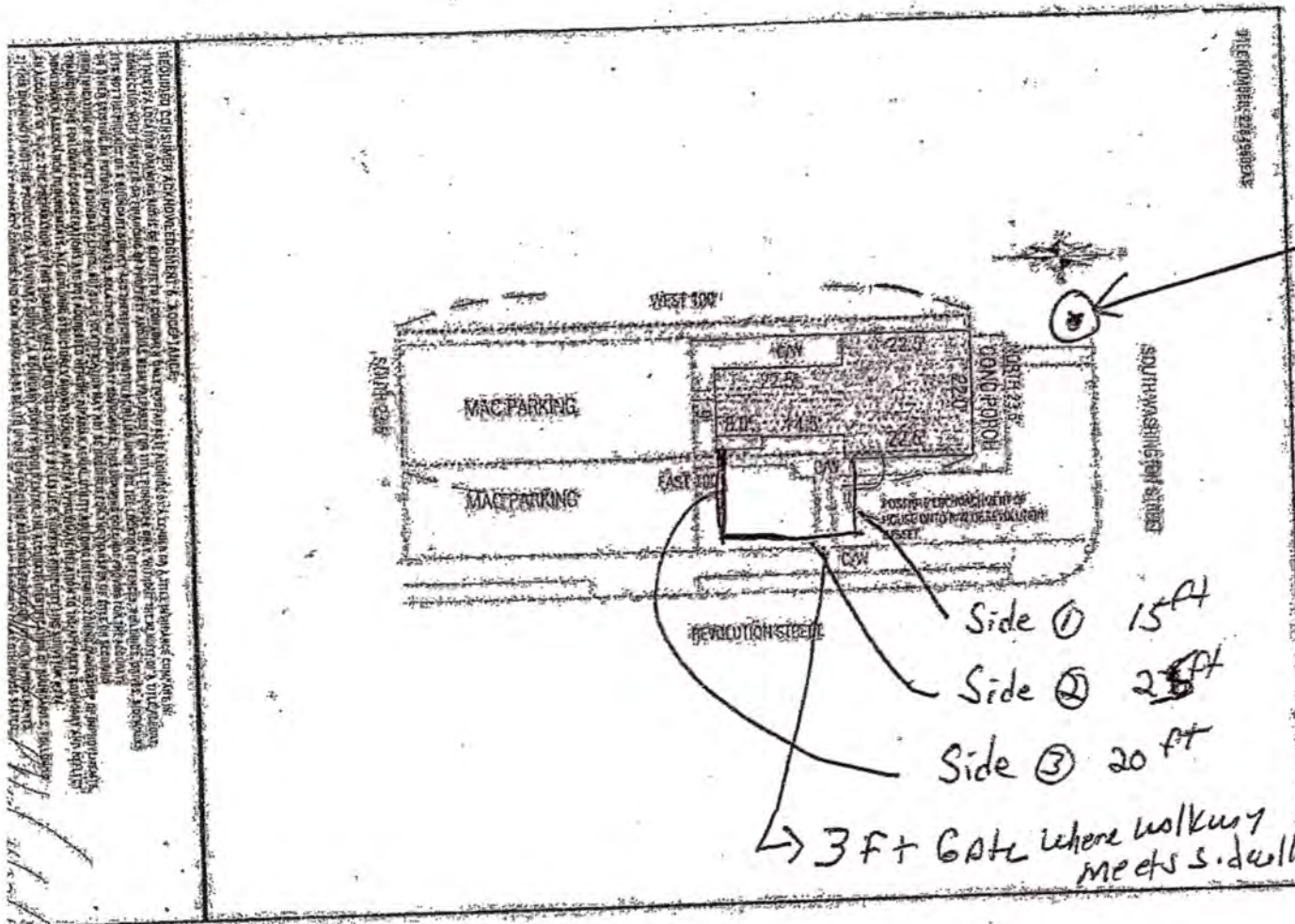

Water CROCK

3 ft Tall picket Fence

- Side ① 15 ft
- Side ② 25 ft
- Side ③ 20 ft

→ 3 ft Gate where walkway meets s. wall



CITY COUNCIL
OF
HAVRE DE GRACE, MARYLAND

ORDINANCE NO. 1049

Introduced by _____ Council Member Ringsaker

AN ORDINANCE OF THE MAYOR AND CITY COUNCIL OF THE CITY OF HAVRE DE GRACE ADOPTED PURSUANT TO THE AUTHORITY OF ARTICLE XI-E OF THE MARYLAND CONSTITUTION, THE LOCAL GOVERNMENT ARTICLE OF THE ANNOTATED CODE OF MARYLAND, AND SECTIONS 33 AND 34 OF THE HAVRE DE GRACE CITY CHARTER, FOR THE PURPOSE OF AMENDING CITY ZONING CODE §205-9 TO ESTABLISH MAXIMUM SETBACKS IN THE NATIONAL REGISTER HISTORIC DISTRICT AND PROHIBIT FRONT LOAD GARAGES ON CERTAIN STREETS.

On: 2/16/2021

at: 7:00PM

Ordinance introduced, read first time, ordered posted and public hearing scheduled.

PUBLIC HEARING

Having been posted and notice of time and place of hearing and title of Ordinance having been published according to the Charter, a public hearing was held on 3/1/2021 at 7:00 p.m., and concluded on 3/1/2021 at 7:04 p.m..

EXPLANATION

Underlining indicates matter added to existing law.

[Bold Brackets] indicate matter deleted from existing law.

Amendments proposed prior to final adoption will be noted on a separate page with line references or by handwritten changes on the draft legislation.

§205-9 Height, lot, yard townhouse and cottage dwelling requirements.

A. Height, lot and yard requirements for each district and use shall be as specified in Table I[.], except for the following:

(1) Single-family and attached dwellings shall have a maximum front yard setback of 5-feet from the right-of-way line when located within the National Register Historic District in order to preserve historic streetscapes and context.

(a) The Director of Planning may require and approve a greater setback if the Director of Public Works identifies conflicts with existing or proposed utilities, or other City assets.

(b) The setback may be increased if the Director of Planning finds that the setback for the majority of existing structures along the block of a street is greater than 5-feet, or a generally consistent structure setback is not observed along the block of a street. If a generally consistent setback is not observed along the same block of a street, then the setback may be increased to a maximum of 10-feet.

(2) Front load garages shall be prohibited from being constructed on or adjacent to existing or proposed dwellings along Union Avenue, Washington Street or Congress Avenue when a lot or parcel also has access to an alley, lane or other side street, unless the proposed garage is setback a minimum of 15-feet from the front façade of the dwelling.

NOW THEREFORE, it is *determined, decided, and ordained by the City Council* that the amendments to City Code Chapter 205 Zoning as set forth above are hereby approved.

In accordance with the provisions of the Maryland Ann. Code, Land Use Article, §4-203 and the City Charter requirements, this ordinance shall become effective no earlier than ten days after the close of the public hearing on the Zoning Code amendments set forth herein.

ADOPTED by the City Council of Havre de Grace, Maryland this __ day of _____, 2021.

SIGNED by the Mayor and attested by the Director of Administration this ____ day of _____, 2021.

ATTEST:

THE MAYOR AND CITY COUNCIL
OF HAVRE DE GRACE, MARYLAND

Patrick D. Sypolt
Director of Administration

William T. Martin
Mayor

Introduced/First Reading: 2/16/2021
Public Hearing: 3/1/2021
Second Reading/Adopted: 3/15/2021
Effective Date: [mm/dd/yyyy]

CITY COUNCIL
OF
HAVRE DE GRACE, MARYLAND

ORDINANCE NO. _____

Introduced by _____ Council Member Zinner

AN ORDINANCE OF THE MAYOR AND CITY COUNCIL OF THE CITY OF HAVRE DE GRACE ADOPTED PURSUANT TO THE AUTHORITY OF ARTICLE XI-E OF THE MARYLAND CONSTITUTION, THE LOCAL GOVERNMENT AND ENVIRONMENTAL ARTICLES OF THE ANNOTATED CODE OF MARYLAND, AND SECTIONS 33 AND 34 OF THE HAVRE DE GRACE CITY CHARTER FOR THE PURPOSE OF AMENDING CITY CODE CHAPTER 169 STORMWATER MANAGEMENT

On: April 5, 2021

at: 7:00 PM

Ordinance introduced, read first time, ordered posted and public hearing scheduled.

PUBLIC HEARING

A Public Hearing is scheduled for April 19, 2021 at 7:00 PM.

EXPLANATION

Underlining indicates matter added to existing law.

[Bold Brackets] indicate matter deleted from existing law.

Amendments proposed prior to final adoption will be noted on a separate page with line references or by handwritten changes on the draft legislation.

32
33

34 The City Council hereby amends City Code, Chapter 169, Stormwater Management as follows:

35

36 §169-37. Conformance required; effective date

37

38 A. Except as specifically exempted by this chapter, all development activity within the City
39 limits of the City of Havre de Grace shall conform to the requirements of these
40 **[documents]** Code provisions.

41

42 B. Developments with stormwater management and erosion and sediment control plans
43 **[approved as of June 17, 2010,]** shall be exempt from the revised design requirements of
44 this chapter, provided that:

45

46 (1) The stormwater management and sediment control plans were approved prior to May
47 4, 2013 and as-builts were submitted and approved prior to May 4, 2017
48 **[Construction is actively progressing on the site in accordance with the approved**
49 **erosion and control plan];** and

50

51 (2) **[The erosion and sediment control plan(s) remain active and all necessary**
52 **approvals for updates and revisions are obtained through the District; and]**
53 The exemption provided under this section is no less stringent than any exemption
54 allowed under the grandfathering provisions of the Maryland Code Annotated,
55 environmental Article, Title 4, Subtitle 2 and regulations promulgated thereunder; and

56

57 (3) The original site design and total impervious area have not been altered from the
58 original plan submission.

59

60 C. Be it further enacted that this chapter shall take effect June 17, 2010.

61

62 **NOW THEREFORE**, it is determined, decided, and ordained by the City Council that
63 foregoing amendments are hereby approved.

64

65 **ADOPTED** by the City Council of Havre de Grace, Maryland this 3rd day of May, 2021.

66

67 **SIGNED** by the Mayor and attested by the Director of Administration this 4th day of May, 2021.

68

69 ATTEST: THE MAYOR AND CITY COUNCIL
70 OF HAVRE DE GRACE, MARYLAND

71

72 _____

73 Patrick D. Sypolt
74 Director of Administration

75

76 _____
77 William T. Martin
78 Mayor

76 Introduced/First Reading: 04/05/2021

77 Public Hearing: 04/19/2021

78 Second Reading/Adopted: 05/03/2021

79 Effective Date: 05/04/2021

Good Afternoon Everyone;

In an attempt to answer Councilwoman Boyer's question concerning the amendment proposal to Chapter 169 Stormwater Management ~ Grandfather provision (in the READ file) and be proactive in assuming others of our City Council may have similar questions I offer the following background in support of the ordinance amendments.

In 2009, MDE began tightening their stormwater regulations and the county and municipal governments were put on notice of the upcoming changes. By law, the County and municipalities can have more stringent regulations but cannot have less restrictive regulations than the State. This applies to all State laws.

When the City rewrote the stormwater ordinance they made the ordinance more restrictive in certain aspects than the State's law. It was done during a time in response to some challenges they were facing with some developers. Little did the authors realize that eleven years later, some proposed sites would still be under development and as a result, regulated by the provisions of Ordinance 169.

The proposed amendments will lessen the negative impact the ordinance has on developers that have maintained good practices and are in good standing with the City while achieving the intentions Ordinance 169 was authored for and mirrors the Maryland Code in this regard.

If you have any questions or require further clarification please don't hesitate to ask me.

Respectfully yours,

A handwritten signature in cursive script, appearing to read "Patrick".

Patrick

PROCEEDINGS OF CITY COUNCIL MEETING

April 5, 2010

City of Havre de Grace, Maryland

The regular meeting of the Mayor and City Council was called to order on April 5, 2010 at 7:00 pm with Mayor Wayne H. Dougherty presiding and the following members present: Council President Craig, Councilmember's Cullum, Martin, Shank, and Miller and Guldenzopf. The Pledge of Allegiance was led by Mayor Dougherty and the opening prayer was performed by Chaplain Nick McDonald of Upper Chesapeake Health.

On motion by Councilmember Shank and seconded by Councilmember Cullum and on six affirmative votes, the minutes of March 15, 2010 were approved.

Mayor Dougherty removed item 6B from the agenda. "Did You Know" awards. Employees are in training.

RECOGNITIONS: (Presented by Mayor Dougherty)

Recognition was presented to Student of the Month from Meadowvale Elementary School, Miss. Dachele Johnson.

PRESENTATIONS: None

PROCLAMATIONS: None

OATH OF OFFICE: None

COMMENTS FROM THE CITIZENS ON AGENDA ITEMS:

Charles Packard Sr., 712 Shawnee Brook Drive, Havre de Grace: Mr. Packard is the President of the Susquehanna Hose Company. Commented on item 10B, stated funding is important and appreciates continued support. He appreciates Council reaching out to both the Susquehanna Hose Company and Ambulance Corps.

Joe K, Tydings Road; commented on item 10A, Mr. K offered his personal observations and opinions. He asked the Council to consider putting Opera House Resolution on hold. Feels that the Old City Hall does not represents a Visitors Center and feels that Old City Hall does not have welcoming appearance. He stressed that the current Visitors Center should remain. Old City Hall has a conservative image and cannot be changed without hurting the historical value. He does not agree with demolishing the current Visitors Center and making it into parking. Owners and employees should not park in front of their own businesses.

Phil Barker, 101 McSpadden Drive, Former Mayor of Havre de Grace, New President of Maritime Museum. Mr. Barker thanked the Mayor and Council for there continued support and financial support. Commented on three important events that relate to the success of the Maritime Museum; these events are Wooden Canoe Event, Marifest and HDG Triathlon.

Marsha Jacksteit, 409 Girard, President of Friends of Concord Point Lighthouse; Asked for support for the upcoming event, re-dedication of the John O'Neil Cannon Memorial.

Charles Vasilaski, 974 Chesapeake Drive, President of Lockhouse. Asked for support for the event of War 1812 on the Lockhouse grounds. On behalf of all the museums, he thanked the Mayor and Council for the support during the years. Stated support is crucial and thanked the City. Ensures the Mayor

and Council that every museum is working just as hard as the next and they meet to collaborate often. Asking for favorable considerations for funding.

Cecil F. Hill, 505 Concord Street. Stated his support for the May 2, 2010 triathlon event.

RESOLUTIONS:

A RESOLUTION BY THE MAYOR AND CITY COUNCIL OF HAVRE DE GRACE, MARYLAND FOR THE PURPOSE OF DETERMINING THE CURRENT AND FUTURE USE OF THE CITY PROPERTY KNOWN AS THE OLD CITY HALL BUILDING ON UNION AVENUE PURSUANT TO THE AUTHORITY OF ARTICLE 23A OF THE ANNOTATED CODE OF MARYLAND AND CITY CHARTER SECTIONS 4 AND 34.

A motion was made by Councilmember Martin and seconded by Councilmember Craig to introduce Resolution 2010-03. Motion carries 5-1 with Councilmember Shank opposing introduction. After the header was read and assigned a number, a motion was made by Councilmember Miller and seconded by Councilmember Martin to adopt Resolution 2010-03. Motion carries 5-1 with Councilmember Shank opposing the motion.

Councilmember Shank commented he will not support the concept of moving the Visitors Center to the Opera House.

A RESOLUTION BY THE MAYOR AND CITY COUNCIL OF HAVRE DE GRACE, MARYLAND AMENDING CITY RESOLUTION 2001-4 AND ESTABLISHING LEVEL FUNDING FOR THE SUSQUEHANNA HOSE COMPANY, INC. AND THE HAVRE DE GRACE AMBULANCE CORPS.

A motion was made by Councilmember Martin and seconded by Councilmember Cullum to introduce Resolution 2010-04. Motion carries 6-0. A motion was made by Councilmember Guldenzopf to amend the resolution to cover only thru 2014 so that a reassessment could be made. Motion failed for lack of a second. After the header was read and assigned a number, a motion was made by Councilmember Shank and seconded by Councilmember Cullum to adopt Resolution 2010-04. Motion carries 6-0.

AN ORDINANCE DELETING AND REPLACING CITY CODE CHAPTER 169 STORM WATER MANAGEMENT IN ITS ENTIRETY IN ORDER TO BRING THE EXISTING CODE INTO COMPLIANCE WITH THE MARYLAND ANNOTATED CODE ENVIRONMENT ARTICLE.

A motion was made by Councilmember Guldenzopf and seconded by Councilmember Shank to introduce Ordinance 912 on first reading. Motion carries 6-0. After the header was read and assigned a number a motion was made by Councilmember Guldenzopf and seconded by Councilmember Shank to adopt Ordinance 912 on first reading. Motion carries 6-0. A Public hearing is scheduled for April 19, 2010 at 7:00pm.

AN ORDINANCE BY THE MAYOR AND CITY COUNCIL OF HAVRE DE GRACE ADOPTED PURSUANT TO THE AUTHORITY OF ARTICLE XI-E OF THE MARYLAND CONSTITUTION, ARTICLE 23A AND 66B OF THE ANNOTATED CODE OF MARYLAND, AND SECTIONS 33 AND 34 OF THE HAVRE DE GRACE CITY CHARTER, FOR THE PURPOSE OF AMENDING HAVRE DE GRACE CITY CODE CHAPTER 205 ZONING ARTICLE 11 SECTION 205-13 DEFINITIONS.

A motion was made by Councilmember Guldenzopf and seconded by Councilmember Miller to introduce Ordinance 913 on first reading. Motion carries 6-0. After the header was read and assigned a number a motion was made by Councilmember Guldenzopf and seconded by Councilmember Miller to adopt Ordinance 913 on first reading. Motion carries 6-0. A Public hearing is scheduled for April 19, 2010 at 7:00pm.

AN ORDINANCE BY THE MAYOR AND CITY COUNCIL OF HAVRE DE GRACE ADOPTED PURSUANT TO THE AUTHORITY OF ARTICLE XI-E OF THE MARYLAND CONSTITUTION, ARTICLE 23A AND 66B OF THE ANNOTATED CODE OF MARYLAND AND SECTIONS 33 AND 34 OF THE HAVRE DE GRACE CITY CHARTER FOR THE PURPOSE OF AMENDING HAVRE DE GRACE CITY CODE CHAPTER 205 ZONING ARTICLE VII RB RESIDENTIAL BUSINESS DISTRICT SECTIONS 205-26, PRINCIPAL PERMITTED USES AND SECTIONS 205-27 CONDITIONAL USES.

A motion was made by Councilmember Guldenzopf and seconded by Councilmember Miller to introduce Ordinance 914 on first reading. Motion carries 6-0. After the header was read and assigned a number a motion was made by Councilmember Guldenzopf and seconded by Councilmember Cullum to adopt Ordinance 914 on first reading. Motion carries 6-0. A Public hearing is scheduled for April 19, 2010 at 7:00pm.

AN ORDINANCE BY THE MAYOR AND CITY COUNCIL OF HAVRE DE GRACE ADOPTED PURSUANT TO THE AUTHORITY OF ARTICLE XI-E OF THE MARYLAND CONSTITUTION, ARTICLE 23A OF THE ANNOTATED CODE OF MARYLAND, AND SECTIONS 33 AND 34 OF THE HAVRE DE GRACE CITY CHARTER, FOR THE PURPOSE OF AMENDING HAVRE DE GRACE CITY CODE CHAPTER 4 ADULT ENTERTAINMENT

A motion was made by Councilmember Guldenzopf and seconded by Councilmember Shank to introduce Ordinance 915 on first reading. Motion carries 6-0. After the header was read and assigned a number a motion was made by Councilmember Guldenzopf and seconded by Councilmember Shank to adopt Ordinance 915 on first reading. Motion carries 6-0. A Public hearing is scheduled for April 19, 2010 at 7:00pm.

UNFINISHED BUSINESS/OLD BUSINESS: None

NEW BUSINESS:

A motion was made by Councilmember Cullum and seconded by Councilmember Martin to approve special event "Wooden Canoe Rendezvous" Motion carries 5-0; Councilmember Guldenzopf recused herself from voting due to her involvement with the Maritime Museum.

A motion was made by Councilmember Shank and seconded by Councilmember Martin to approve special event "Marifest". Motion carries 5-0, Councilmember Guldenzopf recused herself from voting due to her involvement with the Maritime Museum.

A motion was made by Councilmember Shank and seconded by Councilmember Miller to approve special event "Susquehanna Music and Arts Festival". Motion carries 6-0

A motion was made by Councilmember Miller and seconded by Councilmember Guldenzopf to approve special event "Rededication of the John O'Neil Cannon". Motion carries 6-0

A motion was made by Councilmember Martin and seconded by Councilmember Shank to approve special event "HDG Triathlon". Motion carries 5-0. , Councilmember Guldenzopf recused herself from voting due to her involvement with the Maritime Museum.

A motion was made by Councilmember Guldenzopf and seconded by Councilmember Shank to approve special event "War of 1812". Motion carries 6-0

A motion was made by Councilmember Guldenzopf and seconded by Councilmember Cullum to approve license agreement for Susquehanna Hose Company Station #3- Market St to establish new Parking on Fountain St. This parking is located in the City right-of-way. Motion carries 6-0.

A motion was made by Councilmember Guldenzopf and seconded by Councilmember Miller to approve the free standing sign in the City right-of-way; 1126 South Washington St. Motion carries 6-0.

A motion was made by Councilmember Guldenzopf and seconded by Councilmember Miller to approve the block patio with fireplace/chimney and wall in City right-of-way; 600 Lewis St. Motion carries 6-0.

A motion was made by Councilmember Guldenzopf and seconded by Councilmember Miller to approve free standing sign in City right-of-way; 611 South Union Ave. Motion carries 6-0.

BUSINESS FROM THE MAYOR:

Carol Mathis- Director of Administration:

The Franklin Street project will begin in the next few weeks. A pre-construction meeting will be held on April 6, 2010.

The Five point project will start before August.

Neal Mills- Director of Planning:

Requested extensions and received approvals from Maryland Department of Planning for our state mandated Water Resource and Municipal Growth elements.

In the process of reviewing Critical Area requirements for two projects- Fire House #3 addition and new boat ramp at Tydings Park.

George DeHority- Director of Finance:

Primary effort is working on the Budget

Wrapping up third quarter results

Will be meeting with FEMA

Larry Parks- Director of DPW

FRANKLIN STREET STREETScape PROJECT: Contract awarded, pre-*construction* meeting will be held on Wednesday April 7, 2010 at City Hall. Businesses will be notified and construction should start the following week.

BOURBON STREET WATER LINE IMPROVEMENT: Advertising and engineering completed and the pre bid meeting will be held on April 7, 2010 at 9:30 am at City Hall in the large conference room. The bid opening for this project will be held in council chambers on April 21, 2010 at 2pm.

US40/LEWIS LANE WATER MAIN CROSSING : Advertising and engineering completed and the pre bid meeting will be held on April 7, 2010 at 11am in the large conference room. The bid opening for this project will be held in council chambers on April 21, 2010 at 3pm.

BLOOMSBURY AVE., ERIE ST. AND LOCUST RD., SANITARY SEWER REHAB. : Approx. 50% complete, waiting on pre cast vault. This project is scheduled to be completed by the end of April.

OLD BAY LANE: Engineering and surveying services are in the process of being re-bid with a new scope of services. We expect to have this completed by the middle of May.

LEWIS LANE PAVING: Plans are in the process of being reviewed by the city attorney and CSX's attorney.

WATER SYSTEM IMPROVEMENT PHASE III: Engineering bid's due by April 9, 2010.

PAVING PROGRAM: Paving for Tidewater drive will start as soon as the weather permits. (Road temperature must be 60 degree and climbing). Residents will be provided at least two weeks notice.

TYDINGS PARK ELECTRICAL UPGRADE: Received quotes. Lowest bidder has been notified.

Chief Walter- Police Department

Vandalism at the Maritime Museum has been reported. Please contact the Police Department if you have information related to this.

Increased number of calls has been received regarding dogs and bicycles on the promenade. Chief Walter reminded everyone that dogs and bicycles are not allowed on the promenade.

The police department is gearing up for special events throughout the summer time.

The Chief reminded everyone who is a business owner not to park in customer parking.

Mayor's Report-

There is a new business in downtown HDG. The store is called Pizzazz. A variety of gifts and party supplies are available. The store is located on 220 North Washington Street.

Young at Heart meets on Wednesdays at 10am at the Community Activity Center.

BUSINESS FROM THE COUNCIL PRESIDENT:

The City of HDG has been represented at MML for the past year by Councilmember Cullum.

Councilmember Cullum will be running for an elected position on the Board of Directors for MML.

BUSINESS FROM COUNCIL:

Councilmember Martin:

The next Parks and Harbor meeting will take place on April 8th at 4pm.

Councilmember Miller:

Two new bathrooms were installed at the pumping station.

Councilmember Miller reminded everyone to clean up after their dogs.

Councilmember Guldenzopf:

Comprehensive Zoning Review Committee meets the first and third Tuesday of the Month.

Councilmember Guldenzopf will be making a report at the next Council meeting.

Councilmember Shank:

Last week, Don Oman, Council President Craig, Superintendent of schools Tombeck and Mary Ann Lisanti met to discuss future magnet school for HDG.

Made the suggestion that the local businesses should have cost deferred for initial listing on the tourism website.

April 9th, Fellowship of Christian athletes will present former Denver Bronco player, Steve Pitso. He will be speaking about topics that teenagers face today. This is open to the public and will be held at HDG High School.

This weekend the Union gallery located on Union Ave will have a special show. Call Tourism or Mainstreet for further details.

The Painted Lady will have a special exhibit on Saturday evening.

Warren St Art Gallery and other art galleries will participate with the "Art Crawl!"

On April 27, from 6-8 @ the Art Gallery will host special exhibit for art students from HDG High School.

This is under the direction of Jenna Zimmerman. Councilmember Shank commented that he will not support the budget due to the current economic times.

Councilmember Cullum:

Suggested that if Citizens want to obtain the facts about the budget to attend a budget hearing. Reminded everyone to complete there Census and explained the importance.

Stated as a City body, we should thank all the museums for their hard work and dedication. Also stated he is glad to hear all the museums are working together.

COMMENTS FROM CITIZENS:

Betty Coakley, Girard Street:

Would like the Mayor and Council to review plans for a Tourism center at David Craig Park.

Asked why Havre de Grace does not have a Magistrate Court. Expressed this would be convenient for the Citizens of HDG.

Commented that she feels safer with the Police Department on Bicycle's.

Sharon Duncan, Locust Rd.

Expressed her opinion concerning on the preparation of the fiscal year budget.

Mayor Dougherty stated he has an open door policy and he assures Mrs. Duncan there is no hiding of salaries.

He reiterated that the City has had a 7 cent drop in property tax and we will be 5 cent below the constant yield based on his preliminary budget.

Allan Fair, Concord Place;

Stated that auxiliary police would be a great asset to the City.

Kevin Racine, Erie St:

Expressed when rates are increased it affects many disabled citizens.

Tom Fitzpatrick:

Expressed thanks to Brenda Guldenzopf and Carol Mathis

The Lockhouse grand re opening will be April 10th, 2010 @2pm.

Charles Packard 712 Shawnee Brook Drive:

Thanked Mayor and Council and express gratitude for level funding.

A motion was made by Council President Craig and seconded by Councilmember Cullum to proceed in accordance with Section 10-508 of the Annotated Code of Maryland, the Havre de Grace City Council will meet in closed session on Monday, April 5th, 2010 at the conclusion of the regularly scheduled City Council Meeting. The purpose of this closed session is to seek legal counsel from the City Attorney regarding potential property acquisition.

A motion was made by Councilmember Shank and seconded by Councilmember Miller to adjourn at 9:26pm.



April 19, 2010 @7:00 pm

Public Hearing Ordinance 912 (7:00pm)

During the citizen's comments on the proposed Stormwater Management Ordinance, Mr. Kochenderfer offered a list of syntax changes. In addition, he questioned if the City could impose more than the minimum requirements for areas such as Lily Run; an explanation of disconnection of roof-top and non-roof top runoff as it pertains to gutters/downspouts and sump pumps respectively; the difference between a 12 and 24 month maintenance bond stated in the ordinance; confirmation that the Department of Planning is authorized waiver authority.

Mr. Mills responded that the City could impose more than minimum requirements and Lily Run is such an example; roof top runoff does not affect gutters and downspouts only directing their flow away from impervious surfaces; non-roof top runoff pertains to re-directing run-off from impervious surfaces such as drive ways to pervious areas; that a 24 month bond was required for current structural storm water management systems and the 12 month bond is for the newly mandated use of non-structural or natural site design features to the maximum extent possible; the Department of Planning does have waiver authority under the new proposed ordinance.

A concerned citizen Gabriela Hunter: 709 Teal Court, Havre de Grace cited examples where stormwater management has been a constant environmental problem. She stated the current ordinance does not work because developers and builders find ways around compliance. Her question is why the new ordinance would be any different?

Mr Mills explained that the new ordinance is much more environmentally friendly, contains much stricter requirements and that it is not the intent of the Department of Planning, the Mayor, nor the City Council to allow developers and builders to circumvent the new stormwater management requirements.

Ordinances 913, 914 (7:17pm)

John Gessner: 11 S. Main Street, Bel Air, MD; is present on behalf of Nick Contis who is trying to develop a Banquet Hall via an amendment to Ordinance 913 or adding to Ordinance 914. Mr. Contis will follow the recommendations of Council. Drafting stand point would be up to Council.

Joe K, Tydings Road; Ordinance 913; Would like the Council to consider defining "what temporary parking is", define what retail sale is; leaves for interpretation of what cannot be used.

Ordinance 914: Section S- Museum, Mr. K. states this is not required since Museum is covered in Cultural Arts Center, definition in present Ordinance.

Mr. K also states that lot specifications should be identified for the last five items listed in the last page.

Let the record reflect that Mr. K has sent all suggestions discussed this evening to Mayor and Council via email.

Ordinance 915: (7:26pm)

Mr. K, Tydings Road; Section 4-1, would like the Council to consider adding "material" and including "book, magazine...." Seems as if such places as convenience stores may be affected which were not in violation previously. Section 4-2, previously seemed to apply to live performances in the definition of "Patently offensive sexual performances" and now would apply across the board to inanimate as well.

PROCEEDINGS OF CITY COUNCIL MEETING

April 19, 2010

City of Havre de Grace, Maryland

The regular meeting of the Mayor and City Council was called to order on April 19, 2010 at 7:29 pm with Mayor Wayne H. Dougherty presiding and the following members present: Council President Craig, Councilmember's Cullum, Martin, Shank, and Miller and Guldenzopf. The Pledge of Allegiance was led by Mayor Dougherty and the opening prayer was performed by Councilmember Shank.

On motion by Councilmember Martin and seconded by Councilmember Guldenzopf and on six affirmative votes, the minutes of April 5, 2010 were approved.

RECOGNITIONS: (Presented by Mayor Dougherty and Councilmember Shank)

Fire Fighter recognitions were presented to Captain James Sampson for the month of March; Incentive Program Fire Fighters of the Year were presented to Captain Ron Cardwell, Firefighter Gail Reeder, and Lieutenant Gene Burchett. Not present to accept awards were they following: Captain Bob Goll Jr., Lieutenant's Billy Lamana and Shawn Hurst.

PRESENTATIONS:

Mr. Bill Watson; Chairman of the Tourism Advisory Board read into the record the response for a request of a statement regarding listing of Havre de Grace Businesses and their relationship with the tourism website.

Suzanne Streeter of Harford County Government updated Mayor and Council to the HUD Annual Action Plan.

Hollee Sifford and Debbie Leodore of American Cancer Society and Relay for Life presented Mayor and Council a plaque for the continued support and presented Chief Walter with a certificate of appreciation.

PROCLAMATIONS:

A Proclamation was presented by Mayor Dougherty to the Havre de Grace Heritage Museums for collaborating and joining forces.

OATH OF OFFICE: None

COMMENTS FROM THE CITIZENS ON AGENDA ITEMS:

Betty Coakley, Girard Street: Commented the City is fulfilling all responsibilities as a municipal government.

With no objections from Council the Council meeting was recessed at 8:33pm.

The Council meeting was re-convened by Mayor Wayne Dougherty at 8:47pm

RESOLUTIONS:

A RESOLUTION OF THE MAYOR AND CITY COUNCIL OF HAVRE DE GRACE, MARYLAND PURSUANT TO THE AUTHORITY OF THE HAVRE DE GRACE CITY CHARTER, SECTION 76 APPROVING OF A LEASE OF CITY PROPERTY BY RESOLUTION TO DMC PROPERTIES

A motion was made by Council President Craig to introduce resolution 2010-05 and seconded by Councilmember Cullum. Motion carries 6-0. After the header was read and assigned a number a motion was made by Council President Craig and seconded by Councilmember Martin to adopt Resolution 2010-05. Motion carries 6-0.

AN ORDINANCE BY THE MAYOR AND CITY COUNCIL OF HAVRE DE GRACE ADOPTED PURSUANT TO THE AUTHORITY OF ARTICLE XI-E OF THE CONSTITUTION OF MARYLAND AND THE PROVISIONS OF SECTION 2 OF ARTICLE 23A OF THE ANNOTATED CODE OF MARYLAND AND ANY AMENDMENTS THERETO, TITLED "CORPORATIONS - MUNICIPAL," THE ENVIRONMENT ARTICLE OF THE ANNOTATED CODE OF MARYLAND AND ANY AMENDMENTS THERETO, AND SECTION 37 OF THE CITY CHARTER, FOR THE PURPOSES OF ENACTING THIS ORDINANCE NO. 916 ESTABLISHING THE CITY WATER AND SEWER RATES FOR THE FISCAL YEAR JULY 1, 2010 TO JUNE 30, 2011.

A motion was made by Councilmember Cullum to introduce Ordinance 916 on first reading and seconded by Councilmember Craig. Motion carries 5-1 with Councilmember Shank opposing the motion. A motion was made by Councilmember Cullum and seconded by Council President Craig to adopt Ordinance 916. Council President Craig made a motion which was seconded by Councilmember Shank to amend Ordinance 916 leaving the water & sewer rates unchanged for FY 2011. After explaining the rationale of the proposed amendment and upon a roll call vote of 4 in favor and 2 opposed, the amendment to Ordinance 916 was approved. Councilmember's Cullum and Guldenzopf were opposed to the amendment. Upon a roll call vote of 4 in favor and 2 opposed, Ordinance 916, as amended, was approved on first reading. A Public Hearing is scheduled for May 3, 2010 @ 7:00.

AN ORDINANCE BY THE MAYOR AND CITY COUNCIL OF HAVRE DE GRACE, MARYLAND, PURSUANT TO THE AUTHORITY PROVIDED BY THE ANNOTATED CODE OF MARYLAND TAX-PROPERTY ARTICLE TITLE 6 AND THE ANNOTATED CODE OF MARYLAND ARTICLE 23A, FIXING THE TAX RATE FOR THE FISCAL YEAR JULY 1, 2010 TO JUNE 30, 2011 ON EACH ONE HUNDRED DOLLARS (\$100.00) OF ASSESSABLE REAL PROPERTY, PERSONAL PROPERTY; AND PROVIDING AN ADDITIONAL SPECIAL TAX LEVIED WITHIN THE CRITICAL AREA SPECIAL TAXING DISTRICT.

A motion was made by Councilmember Cullum and seconded by Council President Craig to introduce Ordinance 917 on first reading. Motion carries 5-1, with Councilmember Shank opposing motion. After the header was read and assigned a number and explaining the rationale of Ordinance, a motion was made by Councilmember Cullum and seconded by Council President Craig to adopt Ordinance 916 on first reading. Motion carries 4-2 with Councilmember's Shank and Miller opposing the motion. A Public Hearing is scheduled for May 3rd@ 7pm.

UNFINISHED BUSINESS/OLD BUSINESS:

Councilmember Miller gave a copy of 17 proposed changes to Ordinance 913 and Ordinance 914. Councilmember Miller will propose these changes on May 3, 2010.

The Planning Committee Meeting has reviewed these changes.

NEW BUSINESS:

A motion was made by Council President Craig and seconded by Councilmember Guldenzopf to approve the lease for DMC properties. (Chiapparelli's) (Formally Ken's Steak House) Motion carries 6-0.

A motion was made by Councilmember Miller and seconded by Councilmember Shank to approve the Lockhouse Festival walk/run. Motion carries 6-0.

BUSINESS FROM THE MAYOR:

Carol Mathis- Director of Administration:

Ribbon Cutting will take place on the North Park/Joe k Trail on May 15, 2010 @10am starting at the Lockhouse.

Neal Mills- Director of Planning:

Final inspection for Chiapparellis' and U & O issued.

Issued U &O for DJ Liquidators and also completed final inspection.

Sent final notice for 517 S. Stokes Street. The owner has 30 days to respond or the house will be demolished.

George DeHority- Director of Finance:

Mr. DeHority is following up with budget requests from the Budget Hearings.

Closed third quarter and a report will be forthcoming.

Preparing and coordinating for 2010 Audit to begin in June.

Larry Parks- Director of DPW

May 10, 2010 City Contractor will be reconstructing Franklin Street, foot traffic will be allowed accommodations will be made for deliveries.

City has been flushing fire hydrants at night.

Reminded car traffic to be aware of the DPW crew working.

Chief Walter- Police Department

Commented on the Women's 5K by the Bay that will be happening this weekend on April 25th; anticipating 600 runners in Havre de Grace.

May 1-2nd, many activities are taking place and she is asking that citizens use caution when they are in town.

Mayor's Report-

Read into the record, Nancy Jacob's letter regarding highway user funds.

Read into the Record from the April 16th Record newspaper, "Havre de Grace Notice of real property taxes"

Read into the record a statement that was read at the April 8th 2010 budget hearing.

Read into the record Quarterly Fiscal 2010 Financial Results; copies were distributed to Council.

Business from the Council President:

No comments.

BUSINESS FROM COUNCIL:

Councilmember Miller:

Councilmember Miller received and email from Pam Wexler and request a copy is attached to the minutes. Councilmember Miller deferred reading the email into the record.

Councilmember Miller stated that he has accomplished many projects through teamwork in the last four years.

Mr. Miller feels that every downtown business should be listed on the HDG website to increase visitors and revenue for the downtown business area.

Councilmember Guldenzopf:

Distributed a Comprehensive Zoning Review report that reflects the Executive Order #2009-1. Report was read into the record.

The Havre de Grace Triathlon is approaching us and there are spots available.

Councilmember Guldenzopf urges citizens to vote for the candidate that is willing to work with the City

Councilmember Shank:

Would like the Council to show the citizens that we support them in economic times without giving steps and colas.

Commended Mr. Parks and DPW for scheduling the Franklin Street project around First Friday's.

Would like to go on the record and state he supports Christmas bonuses however he suggests the City employee should spend their bonus in a downtown business.

April 29th, 2010 is the Liquor Board Presentation to all non profits organizations.

Arts Crawl will be held Sunday April 25th from 12-5.

Councilmember Cullum:

Councilmember Cullum feels that while on Council he has helped the City grow and prosper.

Councilmember Martin:

Commented on the 10th annual River-sweep; will take place April 24th. Registration is online.

Blockhouse is having there annual dinner at the Bayou on April 20th @ 6:00.

Commented that some Council has been avoiding Steps and Cola's in the last 4 Budget Hearing Session and his intent is to address this at the next meeting.

Councilmember Martin would like to see the following, to allocate 48,000 to sustain level funding for the Susquehanna Hose Company and Ambulance Corps. He also desires to lower the tax rate to 591/2cents and to provide a side walk on Commerce Street and leading into Tydings Park.

COMMENTS FROM CITIZENS:

Kevin Racine, 900 Erie St:

Mr. Racine would like the community to take action in improving transit in Harford County.

Elected Vice Chair for the Maryland Transportation Administration

Betty Coakley, Girard Street:

Mrs. Coakley feels that Havre de Grace needs a new "we" to help the citizens.

A motion was made by Councilmember Miller and seconded by Councilmember Martin to adjourn at 10:37pm.



Public Hearing: May 3, 2010 @7:02 pm

Public Hearing Ordinance 916:

Mr. Garrett Lytle, Miller Court, Bayview Estates; Supports the recommendation of the water and sewer commission made to maintain the 5% increase of water and sewer rates for the upcoming budget, supports deferral of Capitol projects and COLAS.

Mr. Joe K; Tydings Road; Supports the 5% increase in the water and sewer rates. Feels that the Capitol Cost account balance may look good at the moment but has to last for a twenty year period of time.; Feels the need to protect Capitol Account funds.

Ms. Mattie Miller- 607 Legion Drive; Havre de Grace; Thanked Council President Craig for speaking up on the water and sewer rates. Ms. Miller asked the Council not to raise the tax and water sewer rates.

Public Hearing Ordinances 917: (7:15pm)

Mr. Garrett Lytle, Miller Court, Bayview Estates; Supports Ordinance 917 with 1cent reduction on property tax. Mr. Lytle is concerned with suggestions made for a 4cent reduction that has been spoken about. A 4-cent reduction in property tax would result in a ½ million dollar deficit in the budget.

PROCEEDINGS OF CITY COUNCIL MEETING

May 3, 2010

City of Havre de Grace, Maryland

The regular meeting of the Mayor and City Council was called to order on May 3, 2010 at 7:17 pm with Mayor Wayne H. Dougherty presiding and the following members present: Council President Craig, Councilmember's Cullum, Martin, Shank, and Miller and Guldenzopf. The Pledge of Allegiance was led by Mayor Dougherty and the opening prayer was performed by Reverend Mark Specht from Grace Reformed Episcopal Church in Havre de Grace

On motion by Councilmember Martin and seconded by Councilmember Guldenzopf and on six affirmative votes, the minutes of April 19, 2010 were approved.

RECOGNITIONS: None

PROCLAMATIONS: (Presented by Mayor Dougherty)

A Proclamation was presented to Mr. Bobby Parker from the Negro League Baseball Museum of Maryland.

A Proclamation was also presented to Miss. Hannah Bress- Founder of the TEAR Program.

PRESENTATIONS: (Presented by Mr. Ron Browning, Chair of Historic Preservation Committee and Council Liaison Bill Martin)

Special Historic Preservation Awards were presented to Gloria Cannizzaro, Grace Reformed Episcopal Church and Allen Fair.

OATH OF OFFICE: None

COMMENTS FROM THE CITIZENS ON AGENDA ITEMS:

Barbara Wagner, 410 North Union Ave; Expressed concerns regarding proposed Ordinance 915 concerning Havre de Grace City Code Chapter 4- Adult Entertainment. Feels that the proposed Ordinance is open for interpretation.

RESOLUTIONS:

A RESOLUTION BY THE MAYOR AND CITY COUNCIL OF HAVRE DE GRACE, ADOPTED PURSUANT TO THE AUTHORITY OF ARTICLE XI-E OF THE CONSTITUTION OF MARYLAND, THE PROVISIONS OF ARTICLE 23A OF THE ANNOTATED CODE OF MARYLAND, AND SECTION 76 OF THE CHARTER OF HAVRE DE GRACE, MARYLAND, TO APPROVE A LEASE OF CITY PROPERTY TO DANA E. CARO, JR., INDIVIDUALLY AND TRADING AS PIEDMONT PROPERTIES, LLC ("CARO"), BY APPROVING OF A LEASE AMENDMENT NO. 2 FOR A PORTION OF THE CITY'S BUILDING LOCATED AT 352 COMMERCE STREET IN TYDINGS PARK.

A motion was made by Council President Craig and seconded by Councilmember Cullum to introduce Resolution 2010-06. Motion carries 6-0. After the resolution was assigned a number and the header was read into the record Council President Craig made a motion and Councilmember Cullum seconded the motion to adopt Resolution 2010-06. Motion carries 6-0 on roll call vote.

A RESOLUTION BY THE MAYOR AND CITY COUNCIL OF HAVRE DE GRACE, ADOPTED PURSUANT TO THE AUTHORITY OF ARTICLE XI-E OF THE CONSTITUTION OF MARYLAND, THE PROVISIONS OF ARTICLE 23A OF THE ANNOTATED CODE OF MARYLAND, AND SECTION 76 OF THE CHARTER OF HAVRE DE GRACE, MARYLAND, TO APPROVE A LEASE OF CITY PROPERTY TO CHESAPEAKE HERITAGE CONSERVANCY, INC. TRADING AS THE SKIPJACK MARTHA LEWIS FOR A PORTION OF THE CITY'S BUILDING LOCATED AT 352 COMMERCE STREET IN TYDINGS PARK.

A motion was made by Council President Craig and seconded by Councilmember Martin to introduce Resolution 2010-07. Motion carries 6-0. After the resolution was assigned a number and the header read into the read, Council President Craig made a motion and Councilmember Guldenzopf seconded the motion to adopt Resolution 2010-07. Motion carries 6-0 on roll call vote.

ORDINANCE NO. 912 AN ORDINANCE DELETING AND REPLACING CITY CODE CHAPTER 169 STORM WATER MANAGEMENT IN ITS ENTIRETY IN ORDER TO BRING THE EXISTING CODE INTO COMPLIANCE WITH THE MARYLAND ANNOTATED CODE ENVIRONMENT ARTICLE

A motion was made by Councilmember Guldenzopf and seconded by Council President Craig to introduce Ordinance 912 on second reading. Motion carries 6-0. A motion was made by Council President Craig to adopt Ordinance 912 and was seconded by Councilmember Miller. Councilmember Guldenzopf made a motion to adopt the changes to Ordinance 912 as discussed at the Public Hearing. Councilmember Cullum asked for the changes to be read into the record. Mr. Mills stated the syntax changes were made by Joe Kochenderfer at the Public Hearing and they consisted of renumbering, typo's and grammatical changes. The second change is to remove the authority to issue waivers and variances from the inspection services to the Director of Planning or his/her designee. Councilmember Cullum the seconded the motion. Upon a roll call of 4 in favor and Council President Craig and Councilmember Shank opposing the motion to amend the Ordinance was approved 4-2. Upon a roll call vote of 5 in favor and Councilmember Shank opposed, Ordinance 912, as amended, was adopted on second reading, 5-1.

ORDINANCE NO 913 AN ORDINANCE BY THE MAYOR AND CITY COUNCIL OF HAVRE DE GRACE ADOPTED PURSUANT TO THE AUTHORITY OF ARTICLE XI-E OF THE MARYLAND CONSTITUTION, ARTICLE 23A AND 66B OF THE ANNOTATED CODE OF MARYLAND, AND SECTIONS 33 AND 34 OF THE HAVRE DE GRACE CITY CHARTER, FOR THE PURPOSE OF AMENDING HAVRE DE GRACE CITY CODE CHAPTER 205 ZONING ARTICLE II SECTION 205-13 DEFINITIONS

A motion was made by Councilmember Guldenzopf and seconded by Council President Craig to introduce Ordinance 913 for second reading. Motion carries 6-0. A motion was made by Councilmember Shank and seconded by Councilmember Martin to adopt Ordinance 913. Under the question, Councilmember Miller made a motion to amend Ordinance 913, Councilmember Martin seconded the motion. The amendments are as follows.

Section A Paragraph 3 Community Residential Facility:

ANY DWELLING LICENSED, CERTIFIED, OR AUTHORIZED BY STATE, FEDERAL, OR LOCAL AUTHORITIES AS A RESIDENCE FOR **EXAMPLE BUT NOT LIMITED TO** CHILDREN OR ADULTS WITH PHYSICAL, DEVELOPMENTAL OR MENTAL DISABILITIES, DEPENDENT CHILDREN OR ELDERLY INDIVIDUALS IN NEED OF SUPERVISION, SUPPORT AND/OR INDEPENDENT LIVING TRAINING. DOES NOT INCLUDE: HALFWAY HOUSE, CRISIS RESIDENTIAL CENTER, OR SECURE COMMUNITY TRANSITION FACILITY. MAY INCLUDE: SPECIALIZED GROUP HOME FOR THE DEVELOPMENTALLY DISABLED, GROUP CARE FACILITY FOR CHILDREN, AND BOARDING HOME.

Paragraph 4 Community Treatment Facility:

ANY DWELLING OR PLACE LICENSED, CERTIFIED, OR AUTHORIZED BY STATE, FEDERAL, OR LOCAL AUTHORITIES AS A RESIDENCE AND TREATMENT FACILITY FOR **EXAMPLE BUT NOT LIMITED TO** CHILDREN OR ADULTS WITH MENTAL DISABILITIES, ALCOHOLISM, OR DRUG ABUSE PROBLEMS NEEDING A SUPERVISED LIVING ARRANGEMENT AND REHABILITATION SERVICES ON A SHORT-TERM OR LONG-TERM BASIS. DOES NOT INCLUDE DETOXIFICATION CENTERS, HALFWAY HOUSE, CRISIS RESIDENTIAL CENTER OR SECURE COMMUNITY TRANSITION FACILITY. MAY INCLUDE ALCOHOL AND/OR DRUG ABUSE TREATMENT FACILITIES AND ADULT TREATMENT FACILITIES.

Paragraph 5 HALFWAY HOUSE ANY DWELLING OR PLACE LICENSED, CERTIFIED OR AUTHORIZED BY STATE, FEDERAL, OR LOCAL AUTHORITIES FOR EXAMPLE BUT NOT LIMITED TO INMATES ON RELEASE FROM MORE RESTRICTIVE CUSTODIAL CONFINEMENT OR INITIALLY PLACED IN LIEU OF SUCH MORE RESTRICTIVE

CUSTODIAL CONFINEMENT, WHEREIN SUPERVISION, REHABILITATION, AND COUNSELING ARE PROVIDED TO TRANSITION RESIDENTS BACK INTO SOCIETY, ENABLING THEM TO LIVE INDEPENDENTLY

Paragraph 7; Removing definition Passenger Terminal and replacing it with **TRANSPORTATION TERMINAL**. - A FACILITY FOR LOADING, UNLOADING, AND INTERCHANGE OF PASSENGERS, BAGGAGE, AND INCIDENTAL FREIGHT OR PACKAGE EXPRESS BETWEEN MODES OF GROUND TRANSPORTATION, INCLUDING BUS TERMINALS, RAILROAD STATIONS, AND PUBLIC TRANSIT FACILITIES.

Paragraph 9: Add Pawn Shop definition to read: **PAWN SHOP**. - A USE ENGAGED IN THE LOANING OF MONEY ON THE SECURITY OF PROPERTY PLEDGED IN THE KEEPING OF THE PAWNBROKER AND THE INCIDENTAL SALE OF SUCH PROPERTY.

Paragraph 11: **BANQUET HALL**. - "BANQUET HALL" MEANS ANY PLACE OF BUSINESS MAINTAINED, IN WHOLE OR IN PART, FOR PUBLIC RENTAL FOR THE PURPOSE OF PRIVATE PARTY EVENTS, WHETHER FAMILY, GROUP, OR CORPORATE IN NATURE, WHERE ACCESS BY THE GENERAL PUBLIC IS RESTRICTED, AND WITH OR WITHOUT THE SALE, SERVING OR CONSUMPTION OF ALCOHOLIC BEVERAGES. ADDITIONALLY, IT MAY HAVE A DANCE FLOOR GREATER THAN TWO HUNDRED (200) SQUARE FEET.

PARAGRAPH 12: **CATERING SERVICE**. - AN ESTABLISHMENT THAT PREPARES SERVES, AND SUPPLIES FOOD IN LARGE QUANTITIES TO BE DELIVERED AND CONSUMED OFF PREMISES, DELIVERIES OF FOOD PRODUCTS OCCUR ON A REGULAR BASIS.

Paragraph 13 **COMMUNITY FACILITY**. - A BUILDING AVAILABLE TO THE PUBLIC FOR COMMUNITY ACTIVITIES, MEETINGS, BANQUETS, PROJECTS, GATHERINGS, AND THE LIKE. A COMMUNITY CENTER MAY BE ABLE TO BE RESERVED BY THE PUBLIC FOR PRIVATE PARTIES AND EVENTS.

PARAGRAPH 14: REPLACE DEFINITION OF FINANCIAL INSTITUTION AND REPLACE IT WITH **FINANCIAL INSTITUTION** - ANY TRUST COMPANY, SAVINGS BANK, INDUSTRIAL BANK, SAVINGS AND LOAN ASSOCIATION, BUILDING AND LOAN ASSOCIATION, COMMERCIAL BANK, CREDIT UNION, FEDERAL ASSOCIATION, INVESTMENT COMPANY, OR OTHER BUSINESS ASSOCIATION, WHICH IS CHARTERED UNDER FEDERAL OR STATE LAW, SOLICITS, RECEIVES, OR ACCEPTS MONEY OR ITS EQUIVALENT ON DEPOSIT AND LOANS MONEY AS A REGULAR BUSINESS.

PARAGRAPH 15: REPLACE DEFINITION TO STATE **LABORATORY**. -AN ESTABLISHMENT WHOSE PRINCIPAL PURPOSE IS THE RESEARCH, COMPOUNDING AND/OR PACKAGING OF SCIENTIFIC PRODUCTS, WHICH MAY INCLUDE LIGHT MANUFACTURING.

PARAGRAPH 16: **MUSEUMS: MUSEUM**. - "MUSEUM" MEANS A BUILDING, PLACE, OR INSTITUTION DEVOTED TO THE ACQUISITION, CONSERVATION, STUDY, EXHIBITION, AND EDUCATIONAL INTERPRETATION OF OBJECTS HAVING SCIENTIFIC, CULTURAL, HISTORICAL, OR ARTISTIC VALUE.

PARAGRAPH 17: **NATIONAL REGISTER OF HISTORIC PLACES**. - THE OFFICIAL LIST, MAINTAINED BY THE NATIONAL PARK SERVICE OF THE UNITED STATES DEPARTMENT OF THE INTERIOR, OF HISTORIC RESOURCES CONSIDERED BY THAT AGENCY TO BE WORTHY OF PRESERVATION.

PARAGRAPH 18: **RECEPTION OR MEETING HALL**. - ALSO KNOWN AS A RENTAL HALL OR A BANQUET HALL, A BUILDING, FACILITY, ROOM, OR PORTION THEREOF, WHICH IS RENTED, LEASED OR OTHERWISE MADE AVAILABLE TO ANY PERSON OR GROUP FOR A PRIVATE EVENT OR FUNCTION, THAT IS NOT OPEN TO THE GENERAL PUBLIC, WHETHER OR NOT A FEE IS CHARGED.

PARAGRAPH 19: **SPECIALTY SHOP**. - A SMALL-SCALE (LESS THAN 2,500 SQUARE FOOT) RETAIL USE WHICH OFFERS FOR SALE ITEMS OF ART OR CRAFTS, OR WHICH OFFERS FOR SALE ITEMS RELATED TO A SPECIFIC THEME, E.G., KITCHEN WARES, PET CARE, ETC.

PARAGRAPH 20: **STUDIO, FINE ARTS**. - A BUILDING, OR PORTION THEREOF, USED AS A PLACE OF WORK BY A SCULPTOR, ARTIST, OR PHOTOGRAPHER; OR USED AS A PLACE TO EXHIBIT AND OFFER FOR SALE WORKS OF THE VISUAL ARTS (OTHER THAN FILM).

SECTION B, 2. **PARKING FACILITY**- STRIKE OUT CURRENT DEFINITION OF PARKING FACILITY AND REPLACE WITH **PARKING FACILITY**: A STRUCTURE OR PART OF A BUILDING IN WHICH (A) PARKING SPACE IS PROVIDED, EXCEPT FOR COMMERCIAL OR PUBLIC UTILITY VEHICLES OR DEAD STORAGE; AND (B) SOME OR ALL OF THE PARKING SPACES ARE NON- ACCESSORY. A PUBLIC PARKING FACILITY MAY INCLUDE ACCESSORY OFF-STREET PARKING SPACES LIMITED TO SUCH SPACES WHICH ARE ACCESSORY TO OTHER USES ON THE SAME ZONING LOT.

SECTION B, 3: **PARKING LOT**: A TRACT OF LAND WHICH: IS USED FOR PARKING EXCEPT FRO COMMERCIAL OR PUBLIC UTILITY VEHICLES OR DEAD STORAGE; AND (B) IS NOT ACCESSORY TO A USE ON THE SAME OR ANOTHER ZONING LOT.

SECTION B, 5 **RETAIL SALES**: STRIKE THE CURRENT DEFINITION AND REPLACE WITH THE FOLLOWING: **RETAIL SALES AND SERVICES** - AN ESTABLISHMENT PRIMARILY ENGAGED IN THE RETAIL SALE OF GOODS, SERVICES AND/OR PRODUCTS (INCLUDING BAKED PRODUCTS, ICE CREAM, AND/OR CANDY FOR CONSUMPTION OFF SITE WITH NO SEATING PROVIDED ON SITE), SUCH USES MAY INCLUDE INCIDENTAL FOOD SERVICE.

SECTION B, 6 VISITORS CENTER, VISITORS INFORMATION CENTER OR TOURIST INFORMATION CENTER- A PHYSICAL LOCATION THAT PROVIDED TOURIST INFORMATION TO THE VISITS WHO TOUR THE PLACE OR AREA LOCALLY.

AFTER DISCUSSION REGARDING ORDINANCE 913

A MOTION WAS MADE BY COUNCILMEMBER MILLER AND SECONDED BY COUNCILMEMBER SHANK TO STRIKE PROPOSED AMENDMENT ITEM 13 COMMUNITY FACILITY DEFINITIONS.

A MOTION WAS MADE BY COUNCILMEMBER MILLER AND SECONDED BY COUNCILMEMBER SHANK TO STRIKE THE PROPOSED DEFINITION OF FINANCIAL INSTITUTION AND HOLD EXISTING DEFINITION CODE

A MOTION WAS MADE BY COUNCILMEMBER MILLER AND SECONDED BY COUNCILMEMBER SHANK TO STRIKE THE PROPOSED TEXT IN PARENTHESIS IN THE RETAIL SALE DEFINITION. THE DEFINITION WILL NOW STATE RETAIL SALES AND SERVICES -AN ESTABLISHMENT PRIMARILY ENGAGED IN THE RETAIL SALE OF GOODS, SERVICES AND/OR PRODUCTS SUCH USES MAY INCLUDE INCIDENTAL FOOD SERVICE.

A MOTION WAS MADE BY COUNCILMEMBER MILLER AND SECONDED BY COUNCILMEMBER SHANK TO STRIKE THE TEXT "GROUND" IN PARAGRAPH 7 TRANSPORTATION TERMINAL.

A MOTION WAS MADE BY COUNCILMEMBER CULLUM TO KEEP THE CURRENT DEFINITION OF VISITORS CENTER, SECONDED BY COUNCILMEMBER MILLER.

AMENDMENTS WERE PASSED 6-0 ON ROLL CALL VOTE.

ORDINANCE 913 AS AMENDED WAS PASSED ON ROLL CALL VOTE 6-0.

ORDINANCE NO 914 AN ORDINANCE BY THE MAYOR AND CITY COUNCIL OF HAVRE DE GRACE ADOPTED PURSUANT TO THE AUTHORITY OF ARTICLE XI-E OF THE MARYLAND CONSTITUTION, ARTICLE 23A AND 66B OF THE ANNOTATED CODE OF MARYLAND, AND SECTIONS 33 AND 34 OF THE HAVRE DE GRACE CITY CHARTER, FOR THE PURPOSE OF AMENDING HAVRE DE GRACE CITY CODE CHAPTER 205 ZONING ARTICLE VII RB RESIDENTIAL BUSINESS DISTRICT SECTIONS 205-26, PRINCIPAL PERMITTED USES AND SECTION 205-27 CONDITIONAL USES.

A motion was made by Councilmember Guldenzopf and seconded by Councilmember Miller to introduce Ordinance 914 on second reading. Motion carries 6-0. A motion was made by Councilmember Shank and seconded by Councilmember Miller to adopt Ordinance 914. Under the question a motion was made by Councilmember Miller to amend Ordinance 914, Councilmember Cullum seconded motion. Motion carries 6-0 on amendments. The approved amendments were grammatical and syntax changes to the Ordinance.

Council President Craig and seconded by Councilmember Miller to amend Section L and Section Y, which both currently states only financial institutions, by adding "banks" and financial institutions.

Upon a roll call of six affirmative votes, the amendments were approved.

Further, a motion was made by Councilmember Miller seconded by Council President Craig, to remove Sections "AA", "CC", and "DD" from Conditional Uses in the RB District. A motion was made by Councilmember Martin and seconded by Councilmember Cullum to remove only Sections "AA", "CC", and "DD" from the RB Conditional Uses. Upon a roll call of six votes, the amendment was approved.

On motion by Councilmember Guldenzopf and seconded by Council President Craig, "Item O", Parking Facility, Lot, was changed from a Permitted Use to a Conditional Use. Upon a roll call of six affirmative votes, the amendment was approved.

Upon a roll call of six affirmative votes, the Ordinance 914, as amended, was adopted on second reading.

ORDINANCE NO 915 AN ORDINANCE BY THE MAYOR AND CITY COUNCIL OF HAVRE DE GRACE ADOPTED PURSUANT TO THE AUTHORITY OF ARTICLE XI-E OF THE MARYLAND CONSTITUTION, ARTICLE 23A OF THE ANNOTATED CODE OF MARYLAND, AND SECTIONS 33 AND 34 OF THE HAVRE DE GRACE CITY CHARTER, FOR THE PURPOSE OF AMENDING HAVRE DE GRACE CITY CODE CHAPTER 4 ADULT ENTERTAINMENT

A motion was made by Councilmember Guldenzopf and seconded by Councilmember Miller to introduce Ordinance 915 on second reading. Motion carries 6-0. A motion was made by Council President Craig and seconded by Councilmember Guldenzopf to adopt Ordinance 915. Upon a roll call of 4 in favor and Councilmember's Martin and Miller opposing the motion, Ordinance 915 was approved 4-2.

With no objections from Council, Mayor Dougherty called for a ten minute recess.

Mayor Dougherty reconvened the City Council Meeting at 9:28pm.

UNFINISHED BUSINESS/OLD BUSINESS: None

NEW BUSINESS:

A motion was made by Councilmember Cullum and seconded by Council President Craig to approve the Spring Celebration Special Event Application scheduled for June 12, 2010. Motion carries 6-0.

A motion was made by Council President Craig and seconded by Councilmember Shank to approve the lease between Mayor and City Council and Dana Caro Jr., individually and trading as Piedmont Properties, LLC. Motion carries 6-0.

A motion was made by Council President Craig and seconded by Councilmember Guldenzopf to approve the lease between Mayor and City Council and Chesapeake Heritage Conservancy trading as the Skipjack Martha Lewis. Motion carries 6-0.

BUSINESS FROM THE MAYOR:

Carol Mathis- Director of Administration: None

Neal Mills- Director of Planning: Storm Water Management Ordinance has been a long process. Patrick Sypolt was the lead on this project. Thanked Mr. Sypolt and Mr. Ishak , Mayor and Council for assistance and support.

George DeHority- Director of Finance: Has begun discussions on Health Care for the upcoming year. Happy to report that FEMA application has been submitted and is looking for a favorable return.

Larry Parks- Director of DPW: DPW will be picking up yard waste every Friday. If citizens are interested in Compost, they can call Harford County division of solid waste. May 22 and 29th will be Spring Clean will be located at the Community Center.

Chief Walter- Police Department: Chief Walter informed Mayor and Council of three programs that the PD active in. Click it or Ticket it, Aggressive driving and Impaired Drivers.

Mayor's Report-

Reported the Mayoral Ball was successful and the three non profits that benefited were Heritage Museums, Grace Place and Boys and Girls Club of Havre de Grace.

Election Day is May 3rd, 2010 and polls are open 7am-8pm. Your vote counts.

Young at Heart has many upcoming events.

A 4th grade student from Meadowvale Elementary School was chosen for "If I Were Mayor Contest"

Business from the Council President:

Thanked Mayor and Council for attending the Patriot Program at Meadowvale.

A motion was made by Council President Craig to approve a Huxters Permit and application for the mobile hot dog cart and ice cream truck to be located at Jean Roberts Park, Monday thru Friday, 10-3. Councilmember Miller seconded the motion, motion carries 6-0.

Thanked all six candidates for running in the upcoming election thanked the Chamber of Commerce, Bulle Rock Residence Club and Dr. Jaffe for organizing candidate forums.

Council President stated he appreciates the hard work of the Arts Commission. The Art Commission will be hosting the Baltimore Symphony Orchestra event on May 8th Tickets are being sold at the visitor's center.

BUSINESS FROM COUNCIL:

Councilmember Guldenzopf:

Councilmember Guldenzopf and Brigitte Peters were invited by Senator Ben Cardin to attend Maryland Tourism Day in Washington DC.

Heritage Weekend was successful and thanked Marsha Jacksteit for organizing the 1812 Cannon dedication. Also, thanked the Police Department, DPW, Susquehanna Hose Company and Ambulance Corp for their assistance in the first successful

Councilmember Guldenzopf expressed sincere condolences to the family of Dr. Carrier.

Councilmember Shank:

Councilmember Shank expressed condolences to the family of Dr. Carrier.

Councilmember Shank congratulated Tom Fitzpatrick and Teresa Yost on their marriage.

Reenactment of 1812 was fantastic

Thursday, May 6th at 5:00 will be the next Public Safety Meeting.

Compliments given to Mayor Dougherty for the Harford Cable Network interview he participated in to promote HDG.

Feels that all of Havre de Grace shopping should be listed on the Havre de Grace Tourism website.

Councilmember Shank complimented Carol Mathis for making the Special Event Application easier to use.

Councilmember Cullum:

Thanked the Historic Preservation on all their work for honoring the folks that have preserved buildings in Havre de Grace.

Thanked the Planning Committee for working on the zoning Ordinances.

Appreciates the candidate forum and wishes everyone good luck

Councilmember Martin:

Thanked Mayor and Council for working hard and debating on Ordinances 913, 914, 915.

Congratulated Historic Preservation Committee for the selecting the award recipients. Stated the "right" people are on this committee.

Stated this past weekend was a memorable weekend for Havre de Grace due to the events throughout the City.

Councilmember Martin thanked all candidates that are running for Council and feels it has been a privilege to be a part of this process.

Councilmember Miller:

Councilmember Miller expressed condolences to the family of Dr. Carrier.

The next Ellsworth Shank series will take place at 6:30 on Thursday May 13, 2010.

Councilmember Miller appreciates the candidate forums that were held.

COMMENTS FROM CITIZENS:

Kevin Racine, 900 Erie St:

A transit meeting will be held on May 11th from 6-8; second floor of the Harford County Building in Bel Air to lay out the 2060 vision plan for transit metro through BWI.

Mr. Coakley, expressed concerns with street lighting in various locations in the City. Larry Parks will look into these concerns and initiate repairs if needed.

Bob Robinson, Pink Lane; Expressed the details of his weekend in the City.

A motion was made by Councilmember Miller and seconded by Councilmember Cullum to adjourn at 10:27pm.